



DC (12–24V) Input Module

Cat. No. 1771-IB

Installation Data

To The Installer

This document provides information on:

- important pre-installation considerations
- power supply requirements
- initial handling procedures
- installing the module
- using the indicators for troubleshooting
- module specifications

Pre-installation Considerations

The 1771-IB module is compatible with the following 2 and 3-wire devices:

- DC proximity switches
- photoelectric sensors
- pushbuttons
- limit switches
- float switches
- selector switches

The off-state leakage current of your 3-wire devices should not exceed 3mA.

This module contains input filtering to limit the effect of voltage transients caused by contact bounce and/or radiated electrical noise. The delay due to input filtering is nominally 12 ± 7 ms for turning inputs on, and 20 ± 7 ms for turning inputs off.

Power Requirements

Your module receives its power through the 1771 I/O chassis backplane from the chassis power supply. The module requires 74mA from the output of this supply. Add this to the requirements of all other modules in the I/O chassis to prevent overloading the chassis backplane and/or backplane power supply.

Initial Handling

The dc input module is shipped in a static–shielded bag to guard against electrostatic discharge damage. Observe the following precautions when handling the module.

Electrostatic Discharge Damage



ATTENTION: Under some conditions, electrostatic discharge can degrade performance or damage the module. Observe the following precautions to guard against electrostatic damage.

- Wear an approved wrist strap grounding device, or touch a grounded object to discharge yourself before handling the module.
- Do not touch the backplane connector or connector pins.
- If you configure or replace internal components, do not touch other circuit components inside the module. If available, use a static–free work station.
- When not in use, keep the module in a static–shielded bag.

Installing Your Module

In this section we tell you how to key your I/O chassis, install your module and make your wiring connections.

Keying Your I/O Chassis

Use the plastic keying bands, shipped with each I/O chassis, to key the I/O slots to accept only this type of module.

The module circuit board is slotted in two places on the rear edge. The position of the keying bands on the backplane connector must correspond to these slots to allow insertion of the module. You can key any connector in an I/O chassis to receive this module except for the left–most connector reserved for adapter or processor modules. Place keying bands between the following numbers labeled on the backplane connector:

- Between 4 and 6
- Between 14 and 16

You can change the position of these keys if system redesign and rewiring makes insertion of a different module necessary.

Installing the Input Module

To install the dc input module in your 1771 Series B I/O chassis, follow the steps listed below.



ATTENTION: Remove power from the 1771 I/O chassis backplane and wiring arm before removing or installing an I/O module.

- Failure to remove power from the backplane or wiring arm could cause module damage, degradation of performance, or injury.
 - Failure to remove power from the backplane could cause injury or equipment damage due to possible unexpected operation.
-

1. Turn off power to the I/O chassis.
2. Place the module in the plastic tracks on the top and bottom of the slot that guide the module into position.
3. Do not force the module into its backplane connector. Apply firm, even pressure on the module to seat it properly.
4. Snap the chassis latch over the top of the module to secure its position.
5. Connect the wiring arm to the module.
6. Make wiring connections to the field wiring arm as indicated in Figures 1 and 2.

Connecting Wiring to the Input Module

Connections to the input module are made to the 10 terminal field wiring arm (cat. no. 1771-WA) shipped with the module. Attach the wiring arm to the pivot bar on the bottom of the I/O chassis. The wiring arm pivots upward and connects with the module so you can install or remove the module without disconnecting the wires.



ATTENTION: Observe proper polarity with dc power connections. Reverse polarity, or application of ac voltage could damage the module.

Figure 1
Connection Diagram (2-Wire Devices)

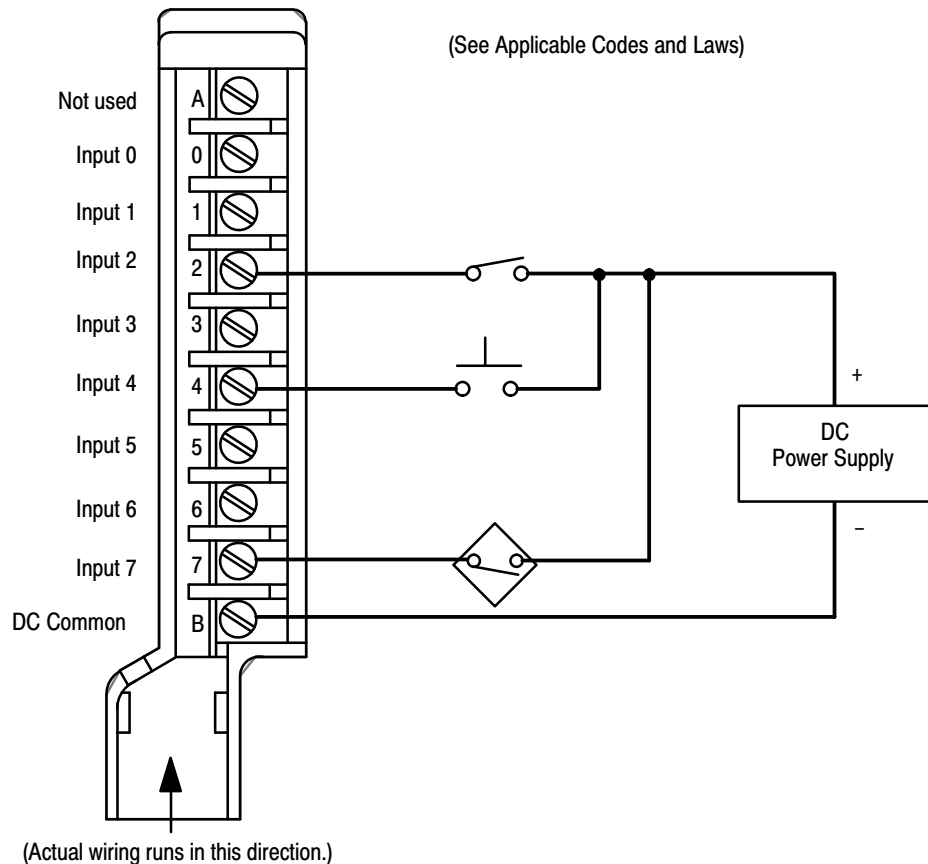

11833-1

Connect one terminal of your 2 or 3-wire input device to terminals 0 through 7 (Figure 1). Connect 3-wire input devices, such as Allen-Bradley proximity switches (Bulletin 871) to operate in a current source mode ().

Connect terminal B to the dc common. Terminal A is not used. Connect the +dc line to the other terminal of your input devices. Use stranded 14 or 16 gauge wire to minimize the voltage drop over long cable distances.

Important: You can directly drive terminals on an DC (12–24V) Input Module (cat. no. 1771-IB) from terminals on the following modules:

- DC (10–60V) Output module (cat. no. 1771-OB)
- DC (12–24V) Output module (cat. no. 1771-OB)

Important: Use the same dc power source to power both modules to ensure that ground is at the same potential.

Figure 2
Connection Diagram (3-Wire Devices)

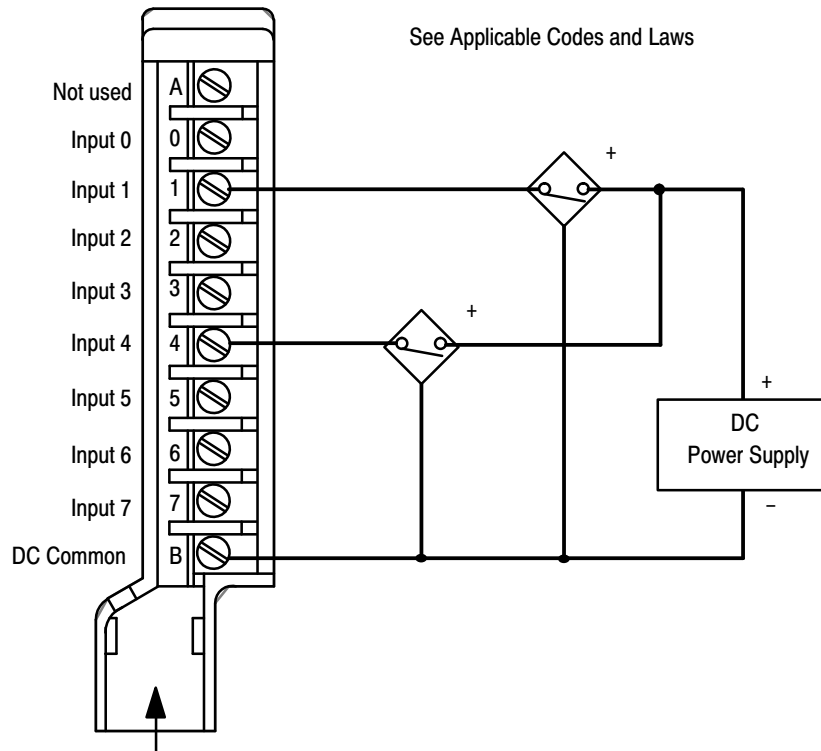

See Applicable Codes and Laws

(Actual wiring runs in this direction.)

11834-I

Interpreting the Status Indicators

The front panel of your module contains 8 red status LED indicators (figure 3). The red status indicators are provided for system logic side indication of individual inputs. When a red LED lights, voltage is present on the terminal. The module transfers this information to the backplane for the processor to read.

Figure 3
Status Indicators

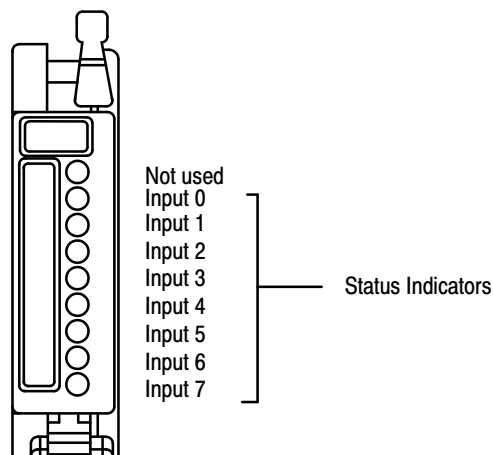

11835-I

Installation Data

DC (12–24V) Input Module
Cat. No. 1771-IB

Specifications

Inputs per Module	8
Module Location	1771 I/O chassis
Input Voltage Range	10 to 27V dc
Nominal Input Current	8mA at 12V dc 24mA at 24V dc
Maximum Off-state Current	3.0mA
Maximum Off-state Voltage	7.0V dc
Minimum On-state Voltage	10V dc
Input Impedance	1 to 2K ohms maximum (on-state) 2 to 3K ohms maximum (off-state)
Input Signal Delay	Low to high propagation delay 12ms \pm 7ms High to low propagation delay 20ms \pm 7ms
Power Dissipation	5.7 Watts (max.), 0.4 Watts (min.)
Thermal Dissipation	19.3 BTU/hr (max.), 1.4 BTU/hr (min.)
Backplane Current	74mA @ 5V dc \pm 5%
Opto-electrical Isolation	1500V ac rms
Environmental Conditions	
Operational Temperature	0° to 60°C (32° to 140°F)
Storage Temperature	-40° to 85°C (-40° to 185°F)
Relative Humidity	5 to 95% (without condensation)
Conductors	14 gage stranded maximum
Wire Size	3/64 inch insulation maximum
Category	2 ¹
Keying	Between 4 and 6 Between 14 and 16
Field Wiring Arm	Catalog Number 1771-WA

¹ Refer to publication 1770-4.1, Programmable Controller Wiring and Grounding Guidelines.



As a subsidiary of Rockwell International, one of the world's largest technology companies — Allen-Bradley meets today's challenges of industrial automation with over 85 years of practical plant-floor experience. More than 11,000 employees throughout the world design, manufacture and apply a wide range of control and automation products and supporting services to help our customers continuously improve quality, productivity and time to market. These products and services not only control individual machines but integrate the manufacturing process, while providing access to vital plant floor data that can be used to support decision-making throughout the enterprise.

With offices in major cities worldwide

WORLD HEADQUARTERS
Allen-Bradley
1201 South Second Street
Milwaukee, WI 53204 USA
Tel: (1) 414 382-2000
Telex: 43 11 016
FAX: (1) 414 382-4444

EUROPE/MIDDLE EAST/AFRICA HEADQUARTERS
Allen-Bradley Europe B.V.
Amsterdamseweg 15
1422 AC Uithoorn
The Netherlands
Tel: (31) 2975/43500
Telex: (844) 18042
FAX: (31) 2975/60222

ASIA/PACIFIC HEADQUARTERS
Allen-Bradley (Hong Kong) Limited
Room 1006, Block B, Sea View Estate
28 Watson Road
Hong Kong
Tel: (852) 887-4788
Telex: (780) 64347
FAX: (852) 510-9436

CANADA HEADQUARTERS
Allen-Bradley Canada Limited
135 Dundas Street
Cambridge, Ontario N1R 5X1
Canada
Tel: (1) 519 623-1810
FAX: (1) 519 623-8930

LATIN AMERICA HEADQUARTERS
Allen-Bradley
1201 South Second Street
Milwaukee, WI 53204 USA
Tel: (1) 414 382-2000
Telex: 43 11 016
FAX: (1) 414 382-2400