

ControlNet Fiber-optic Ring Repeater Modules

Catalog Numbers 1786-RPFRL/B, 1786-RPFRXL/B

Topic	Page
Important User Information	2
Environment and Enclosure	3
North American Hazardous Location Approval	4
Fiber-optic Safety Statements	5
About Fiber Topology	8
Mount the Fiber Modules	11
Choose Fiber-optic Cable for the Module	19
Connect the Cable Between the Repeater Modules	24
Interpret the Status Indicators	28
Specifications	33
Additional Resources	37

About the Module

The ControlNet Fiber-optic Ring Repeater module supports fiber media redundancy by using a ring topology. The fiber-optic technology permits long (1786-RPFRL/B module) or very long (1786-RPFRXL/B module) transmission ranges. Both modules provide optimum protection against EMI effects along the transmission link and at the repeaters themselves. The fiber link provides ground isolation between nodes and is less susceptible to noisy environments than traditional copper media.

Important User Information

Solid-state equipment has operational characteristics differing from those of electromechanical equipment. Safety Guidelines for the Application, Installation and Maintenance of Solid State Controls (Publication [SGI-1.1](#) available from your local Rockwell Automation sales office or online at <http://www.rockwellautomation.com/literature/>) describes some important differences between solid-state equipment and hard-wired electromechanical devices. Because of this difference, and also because of the wide variety of uses for solid-state equipment, all persons responsible for applying this equipment must satisfy themselves that each intended application of this equipment is acceptable.





In no event will Rockwell Automation, Inc. be responsible or liable for indirect or consequential damages resulting from the use or application of this equipment.

The examples and diagrams in this manual are included solely for illustrative purposes. Because of the many variables and requirements associated with any particular installation, Rockwell Automation, Inc. cannot assume responsibility or liability for actual use based on the examples and diagrams.

No patent liability is assumed by Rockwell Automation, Inc. with respect to use of information, circuits, equipment, or software described in this manual.

Reproduction of the contents of this manual, in whole or in part, without written permission of Rockwell Automation, Inc., is prohibited.

Throughout this manual, when necessary, we use notes to make you aware of safety considerations.

	WARNING: Identifies information about practices or circumstances that can cause an explosion in a hazardous environment, which may lead to personal injury or death, property damage, or economic loss.
	ATTENTION: Identifies information about practices or circumstances that can lead to personal injury or death, property damage, or economic loss. Attentions help you identify a hazard, avoid a hazard and recognize the consequences.
	SHOCK HAZARD: Labels may be on or inside the equipment, for example, drive or motor, to alert people that dangerous voltage may be present.
	BURN HAZARD: Labels may be on or inside the equipment, for example, drive or motor, to alert people that surfaces may reach dangerous temperatures.
IMPORTANT	Identifies information that is critical for successful application and understanding of the product.

Environment and Enclosure



ATTENTION: This equipment is intended for use in a Pollution Degree 2 industrial environment, in overvoltage Category II applications (as defined in IEC 60664-1), at altitudes up to 2000 m (6562 ft) without derating.



This equipment is considered Group 1, Class A industrial equipment according to IEC/CISPR 11. Without appropriate precautions, there may be difficulties with electromagnetic compatibility in residential and other environments due to conducted and radiated disturbances.

This equipment is supplied as open-type equipment. It must be mounted within an enclosure that is suitably designed for those specific environmental conditions that will be present and appropriately designed to prevent personal injury resulting from accessibility to live parts. The enclosure must have suitable flame-retardant properties to prevent or minimize the spread of flame, complying with a flame spread rating of 5VA, V2, V1, V0 (or equivalent) if non-metallic. The interior of the enclosure must be accessible only by the use of a tool. Subsequent sections of this publication may contain additional information regarding specific enclosure type ratings that are required to comply with certain product safety certifications.

In addition to this publication, see the following:

- Industrial Automation Wiring and Grounding Guidelines, publication [1770-4.1](#), for additional installation requirements
 - NEMA Standard 250 and IEC 60529, as applicable, for explanations of the degrees of protection provided by enclosures.
-

North American Hazardous Location Approval

<p>The following information applies when operating this equipment in hazardous locations.</p>	<p>Informations sur l'utilisation de cet équipement en environnements dangereux.</p>
<p>Products marked "CL I, DIV 2, GP A, B, C, D" are suitable for use in Class I Division 2 Groups A, B, C, D, Hazardous Locations and nonhazardous locations only. Each product is supplied with markings on the rating nameplate indicating the hazardous location temperature code. When combining products within a system, the most adverse temperature code (lowest "T" number) may be used to help determine the overall temperature code of the system. Combinations of equipment in your system are subject to investigation by the local Authority Having Jurisdiction at the time of installation.</p>	<p>Les produits marqués "CL I, DIV 2, GP A, B, C, D" ne conviennent qu'à une utilisation en environnements de Classe I Division 2 Groupes A, B, C, D dangereux et non dangereux. Chaque produit est livré avec des marquages sur sa plaque d'identification qui indiquent le code de température pour les environnements dangereux. Lorsque plusieurs produits sont combinés dans un système, le code de température le plus défavorable (code de température le plus faible) peut être utilisé pour déterminer le code de température global du système. Les combinaisons d'équipements dans le système sont sujettes à inspection par les autorités locales qualifiées au moment de l'installation.</p>
<div style="display: flex; align-items: center;">  <div> <p>WARNING: Explosion Hazard -</p> <ul style="list-style-type: none"> • Do not disconnect equipment unless power has been removed or the area is known to be nonhazardous. • Do not disconnect connections to this equipment unless power has been removed or the area is known to be nonhazardous. Secure any external connections that mate to this equipment by using screws, sliding latches, threaded connectors, or other means provided with this product. • Substitution of components may impair suitability for Class I, Division 2. • If this product contains batteries, they must only be changed in an area known to be nonhazardous. </div> </div>	<div style="display: flex; align-items: center;">  <div> <p>AVERTISSEMENT: Risque d'Explosion -</p> <ul style="list-style-type: none"> • Couper le courant ou s'assurer que l'environnement est classé non dangereux avant de débrancher l'équipement. • Couper le courant ou s'assurer que l'environnement est classé non dangereux avant de débrancher les connecteurs. Fixer tous les connecteurs externes reliés à cet équipement à l'aide de vis, loquets coulissants, connecteurs filetés ou autres moyens fournis avec ce produit. • La substitution de composants peut rendre cet équipement inadapté à une utilisation en environnement de Classe I, Division 2. • S'assurer que l'environnement est classé non dangereux avant de changer les piles. </div> </div>

Prevent Electrostatic Discharge



ATTENTION: This equipment is sensitive to electrostatic discharge, which can cause internal damage and affect normal operation. Follow these guidelines when you handle this equipment:

- Touch a grounded object to discharge potential static.
 - Wear an approved grounding wriststrap.
 - Do not touch connectors or pins on component boards.
 - Do not touch circuit components inside the equipment.
 - Use a static-safe workstation, if available.
 - Store the equipment in appropriate static-safe packaging when not in use.
-

Fiber-optic Safety Statements



ATTENTION: Laser light can damage your eyes. Laser light is invisible. Looking at it directly does not cause pain. The iris of the eye will not close involuntarily as when you view a bright light. Consequently, serious damage to the retina of the eye is possible.

Never look into the end of a fiber when it may have a laser coupled to it, or directly into fiber ports. Should accidental eye exposure to laser light be suspected, get an eye examination immediately.



ATTENTION: Class 1 laser product. Laser radiation is present when the system is open and interlocks bypassed. Only trained and qualified personnel should be allowed to install, replace, or service this equipment.



WARNING: Hazardous areas require the use of specially designed products. Only when the product is marked accordingly (see the product ID label) it may be used in Class I Division 2 hazardous environments. Rockwell Automation provides similar products that are intrinsically safe and are suitable for more hazardous environments. Use the appropriate products that are designed for the specific hazardous environments that your installation requires.

In intrinsically-safe applications, consult with your local safety coordinator because you need specific products on both ends of the fiber link. Refer to the ControlNet EX Media Planning and Installation Manual, publication [CNET-IN003](#).

TIP You must use an adapter module (1786-RPA/B) with the 1786-RPFRL/B or 1786-RPFRXL/B modules to provide power to all repeaters, and control the flow of data from one repeater to the next.

IMPORTANT The distance between repeaters that can be supported is dependent on the quality of the fiber, number of splices, and connectors. The total loss of the fiber link must be less than 15 dB for the 1786-RPFRL/B module and 10.5 dB for the 1786-RPFRXL/B module.

The total size of the ring or length of the copper and fiber ControlNet network is limited by the ControlNet protocol to 20 km or less. Refer to Determine Maximum Network Length on [page 21](#) for more information.

To determine the maximum distance between any two fiber modules, refer to the table on [page 19](#).

The 1786-RPFRL/B and 1786-RPFRXL/M modules provide the following:

- Two fiber channels
- Activity status indicators for each fiber channel
- Relay contact connector for communication and system status

Figure 1- Module Components

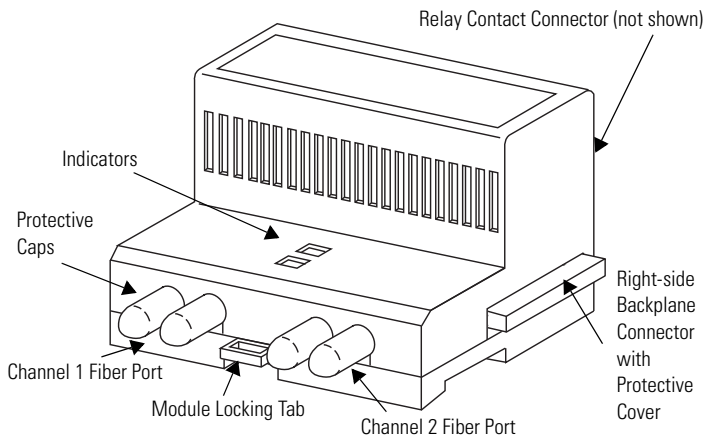

Both sides of the module contain a backplane connector.

42546

About Fiber Topology

The 1786-RPFRL/B or 1786-RPFRXL/B long or extra-long modules can be used to create a redundant optical link between segments. When used in a ring topology, a single media failure between any two repeater modules in a ring will not impact the communication link.

The repeaters detect the failure of an optical link. When a failure occurs, the affected channel port status indicator will be one of the following:

- Red, indicating a faulty link
- Flashing green/off, indicating no network activity is present

Refer to Interpret the Status Indicators on [page 28](#) for more information.

In addition, a relay contact connector on the 1786-RPFRL/B and 1786-RPFRXL/B modules indicates a remote faulty link. See [page 32](#) for more information on the relay contact connector.

We recommend that you install the duplex optical cables of the two optical channels along different routes. For more information on cabling, refer to the ControlNet Fiber Media Planning and Installation Guide, publication [CNET-IN001](#).

The fiber repeater consists of the following:

- A 1786-RPA/B repeater adapter
- Up to two 1786-RPFRL/B or 1786-RPFRXL/B long or extra-long fiber repeater modules
- Up to four 1786-RPCD copper fiber repeater modules
- Up to four 1786-RPFS or 1786-RPFM short- or medium-distance fiber repeater modules

The maximum number of repeater modules (in any combination) you can use in a configuration is dependent on the current draw of each repeater module. Total current draw supplied by the 1786-RPA/B repeater adapter cannot exceed 1.6 A @ 5V DC.

In addition to using the fiber repeater in a ring topology, you can do the following:

- Extend the total length of your segment
- Create a point-to-point or star configuration (multiple directions from one point)
- Provide electrical isolation and immunity to interference
- Use in hazardous areas

The number of fiber repeaters and cable length total limit depends on your network topology.

Example Topology Application

See [page 10](#) for an example topology.

For more information on topology application rules in relation to fiber rings, refer to the ControlNet Fiber Media Planning and Installation Guide, publication [CNET-IN001](#).

IMPORTANT

You cannot have media redundancy if you have a closed loop ring installation anywhere in the network. You may use the 1786-RPFRL/B, 1786-RPFRXL/B, 1786-RPFM, or 1786-RPFS modules in a linear fiber topology.

Do not mix fiber repeater modules to achieve a ring topology and 1786-RPFM modules to achieve a redundant media topology in one configuration.

For additional topology configurations, refer to Allowable Configurations When Using Repeaters in a Ring Topology on ControlNet, Knowledgebase Technical Note [ID 32215](#).

Fiber-optic Ring Topology

Use this configuration for long distances. A fiber-optic ring may contain as many as 20 member modules. These member modules (four shown in [Figure 2](#)) include the following:

- 1786-RPA/B repeater adapter module
- 1786-RPFRL/B long-distance ring repeater module
- 1786-RPFRXL/B extra long-distance ring repeater module

TIP You cannot exceed 20 repeater modules in a series. If a ring is broken, whether accidentally or on purpose for testing, the configuration then becomes linear and the number of repeaters depends on where the ring is broken. Most likely you will have as many repeaters as in the original ring, such as the four shown in [Figure 2](#).

Figure 2 - Fiber Ring Topology Example

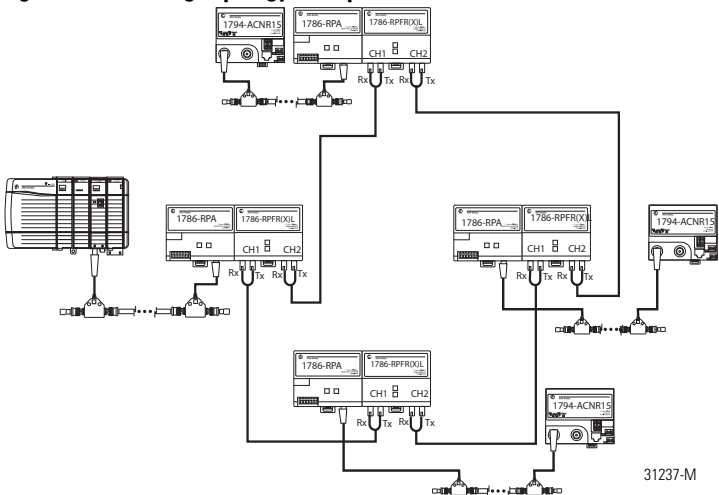

On all fiber repeater modules, the leftmost connector is the RX (Receive) port; the rightmost connector is the TX (Transmit) port.



ATTENTION: Be certain that the adapter and repeater modules are secured together with DIN rail anchors. Failure to do so may result in the loss of communication and/or cause damage to the modules.

The total number of modules that can be attached to the 1786-RPA/B repeater adapter cannot exceed four or the total power consumption of the modules cannot exceed 1.6 A @ 5V DC, whichever comes first. The 1786-RPFRL/B and 1786-RPFRXL/B modules require 570 mA each, therefore you can attach only two of these modules to a 1786-RPA/B repeater module.

If you exceed the module or power limit, you may cause damage to the modules and repeater adapter.

Mount the Fiber Modules

This section explains how to mount the module.

TIP Horizontal mounting is preferred. Vertical mounting is allowed. We recommend that the 1786-RPA/B module be mounted at the top if vertical mounting is chosen.



ATTENTION: This product is grounded through the DIN rail to chassis ground. Use zinc plated yellow-chromate steel DIN rail to assure proper grounding. The use of other DIN rail materials (for example, aluminum or plastic) that can corrode, oxidize, or are poor conductors, can result in improper or intermittent grounding. Secure DIN rail to mounting surface approximately every 200 mm (7.8 in.) and use end-anchors appropriately.

Figure 3 - Mounting Dimensions

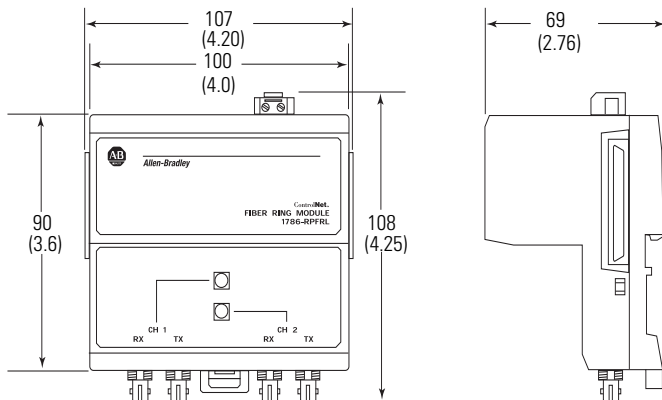

Dimensions are in mm (in.).

31532-M

Horizontal mounting requirements are determined by using the following formula:

$RPA/B \text{ width} + (4.2 \text{ inches} \times \text{number of RPFR}(X)L) + 2 \text{ inches}$

For more information, see the ControlNet Modular Repeater Adapter Installation Instructions, publication [1786-IN013](#).

IMPORTANT Maintain adequate separation from other equipment to guarantee that ambient temperature is within the operating range of this module. You must follow applicable separation codes for safe operation.

Do these steps to mount a module.

1. Position the module on a 35 x 7.5 mm (1.38 x 0.30 in.) DIN rail, Allen-Bradley part number 199-DR1; 46277-3; EN 50022).

- Hook the lip on the rear of the module onto the top of the DIN rail, and rotate the module onto the rail.

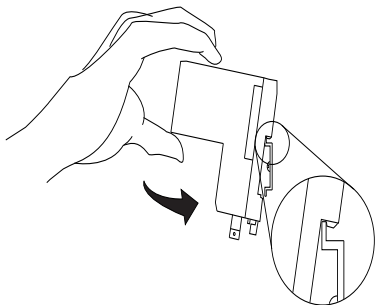

42542

- Press the module onto the DIN rail until flush.

The locking tab should snap into position and lock the module to the DIN rail.

- If the module does not snap into position, use a screwdriver or similar device to retract the locking tab while pressing the module flush onto the DIN rail.
- Release the locking tab to lock the module in place.

If necessary, push the locking tab to lock.

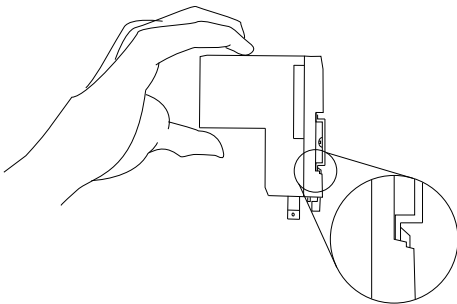

42543



WARNING: Removal and insertion under power (RIUP) is not supported. These modules must be powered down while connecting and disconnecting them from any interconnected modules.

If you insert or remove the module while backplane power is on, an electrical arc can occur. This could cause an explosion in hazardous location installations.

Be sure that power is removed or the area is nonhazardous before proceeding.

6. Remove the protective backplane cap as shown on [page 18](#).



WARNING: When you connect or disconnect the removable terminal block (RTB) with field side power applied, an electrical arc can occur. This could cause an explosion in hazardous location installations.

Be sure that power is removed or the area is nonhazardous before proceeding.

7. Once the modules are attached to the DIN rail, slide them together to mate the repeater adapter with the repeater module.

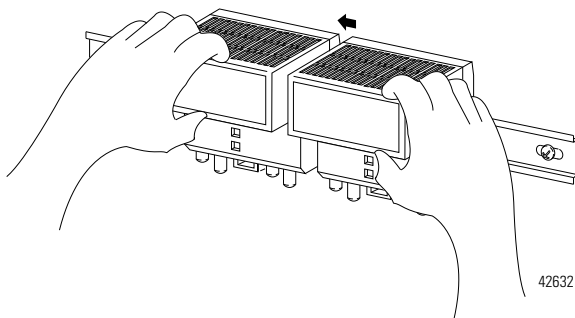

Install the Ferrites

This procedure explains how to set up a ferrite to reduce EMI interference. The ferrite will be connected to the module's relay contact connector.

TIP If you are not planning to use the relay contact connector on the module for system status, you do not need to install the ferrites.

1. Obtain 0.25... 2.5 mm² (22...14 AWG) wire in a length sufficient for your application.

TIP You may want to choose a smaller wire gauge (for example, 0.25...0.823 mm² (22...18 AWG) with sufficient size and rating to handle amperage requirements of the power supply to aid in installation of the ferrite.

2. Twist the wires.

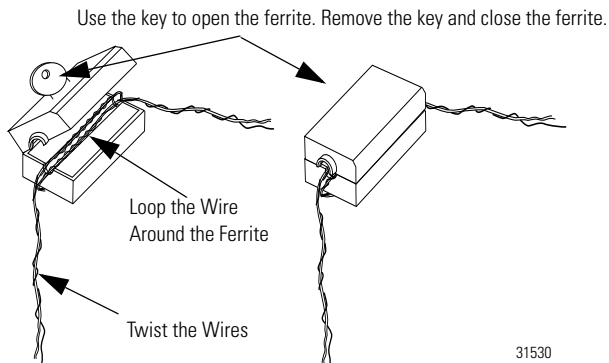

Install the Ferrite at the Power Supply

Do these steps to attach the ferrite to the power supply of the 1786-RPA/B module.

1. Use the key supplied with the ferrite to open it.

Be careful not to damage the wires.

2. Form a loop with both wires (+ and -) approximately 100 mm (4 in.) away from the power supply connector of the 1786-RPA/B module.
3. Loop the wires through the ferrite.
4. Close the ferrite.

Be careful not to damage the wires.

5. Strip approximately 6 mm (0.24 in.) of wire from the end that will connect to the power supply connector on the 1786-RPA/B module.
6. Remove the power supply connector from the 1786-RPA/B module.
7. Install the stripped ends of the wires in the power supply connector on the 1786-RPA/B module as shown below.

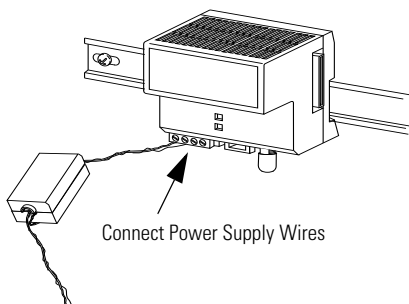

31528

IMPORTANT Do not use more than one ferrite per 1786-RPA/B module.

8. Reinsert the power supply connector into the 1786-RPA/B module.

Install the Ferrite at the Relay Contact Connector

1. Use the key to open the remaining ferrite.
2. Form a loop with both wires (+ and -) approximately 100 mm (4.0 in.) away from the relay contact connector of the 1786-RPFRL/B or 1786-RPFRXL/B module.
3. Loop the wires through the ferrite.
4. Close the ferrite.

Be careful not to damage the wires.

5. Strip approximately 6 mm (0.24 in.) of wire from the end that will connect to the relay contact connector on the 1786-RPFRL/B or 1786-RPFRXL/B module.
6. Remove the relay contact connector from the 1786-RPFRL/B or 1786-RPFRXL/B module.
7. Install the stripped ends of the wires in the relay contact connector on the fiber repeater module as shown below.

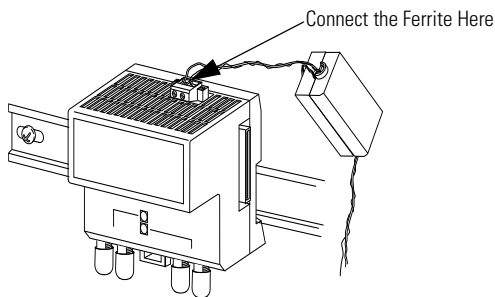

8. Reinsert the relay contact connector into the 1786-RPFRL/B or 1786-RPFRXL/B module.

9. Connect the fiber cable as described on [page 26](#).
10. If you plan not to use a channel, attach a small section of fiber cable (or a Simplex fiber loop) between the Receive port (RX) and the Transmit Port (TX) of any unused fiber port to create a jumper.

Although not required for module operation, the jumper turns the status indicators green and prevents the relay contact connector from opening and indicating a failure.

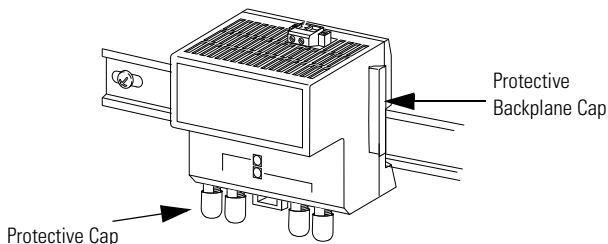

Remove the Protective Caps

1. Remove the protective caps from the fiber ports that you are going to use.
2. Save the caps for future use.

The left side of the module (not shown here) also contains a backplane connector.

If you plan	Then
To place the module in storage	Keep the protective caps on the channels to protect the unit from dust.
To connect another module to the right backplane connector	Remove the protective backplane cap and save the cap for future use.
Not to connect to the right backplane connector	Leave the backplane cap on.



ATTENTION: Do not discard the end cap. Use this end cap to cover the exposed interconnections on the last repeater module on the DIN rail. Failure to do so could result in equipment damage or injury from electric shock.

Choose Fiber-optic Cable for the Module

The type of fiber cable you choose to use depends on the network environment. Consult your installation professional to determine the best type of cable to use for your environmental conditions. Refer to the ControlNet Fiber Media Planning and Installation Guide, publication [CNET-IN001](#), for details.

Understand the Maximum Optical Power Budget

This table shows the maximum optical power budget available for different cable types. Note that the 1786-RPFRL/B module cannot be used with single-mode fiber.

Module	Cable Type	Optical Power Budget	Termination Type
1786-RPFRL/B	62.5/125 μm , multimode, 1300 nm, graded index	15 dB	ST connectors, plastic or ceramic; no metal connectors
1786-RPFRXL/B	62.5/125 μm , multimode, 1300 nm, graded index	10.5 dB	
	9/125 μm , single mode, 1300 nm, graded index		

See [page 20](#) for formulas to determine your optical power budget.

The sample formulas in the example illustrate how you can determine the total loss for fiber-optic cables in your system configuration. The values we use in the formulas are typical: yours may vary, depending on your application.

EXAMPLE Determining total loss for fiber-optic cables

The total loss of the fiber-optic cable between two modules must not exceed the optical power budget. The total loss is the sum of each connector loss plus the loss of the fiber plus the loss associated with the splices in the system, if any. The total loss can be determined as follows:

Total loss = [(loss per connector) x (the number of connectors)] + [(loss per km of fiber) x (km of fiber)] + [(other losses)]

For example, with 2 connectors, each having 0.3 dB of loss, 10 km of multimode fiber with a loss of 1 dB/km, and no splices, the total loss is 10.6 dB. See the following formula:

Total loss = [(0.3 dB x 2) + (1 dB/km x 10 km)]

Total loss = 10.6 dB

This fiber-optic cable is acceptable for use between two 1786-RPFRL/B modules because the total loss is less than the optical power budget of 15 dB. However, this cable could not be used with the 1786-RPFRXL/B module because the total loss exceeds the optical power budget of 10.5 dB.

Determine Maximum Network Length

The quality of the fiber cable determines the maximum distance between modules in a networked system. The delay in the system (described in the following table) determines the maximum length you can achieve with your network.

The worst-case delay (between any nodes) must be less than 121 μ s. This table lists worst-case delays for physical layer components.

Table 1 -Worst-case Delay

Component	Delay
Coaxial cable	4.17 ns/m
Fiber	5.01 ns/m
1786-RPA/B module	901 ns
1786-RPFM module	153 ns
1786-RPFS module	94 ns
1786-RPCD module	100 ns
1786-RPFRL/B 1786-RPFRXL/B modules	100 ns

TIP When determining the worst-case delay for your system, consider how many components you want to use. You can use as many as twenty fiber repeater modules in a ring or series as long as you do not exceed the maximum network length, as determined by the worst-case delay.

The maximum cable distance (that is, the longest route between any two adjacent or non-adjacent nodes) is limited by the ControlNet protocol to 20 km or less. Refer to Determine Maximum Network Length on [page 21](#) for more information.

See [Figure 4](#) on [page 22](#) and the example on [page 23](#) to understand how to determine the worst-case delay for your system.

Figure 4 -Determine Worst-case Delay

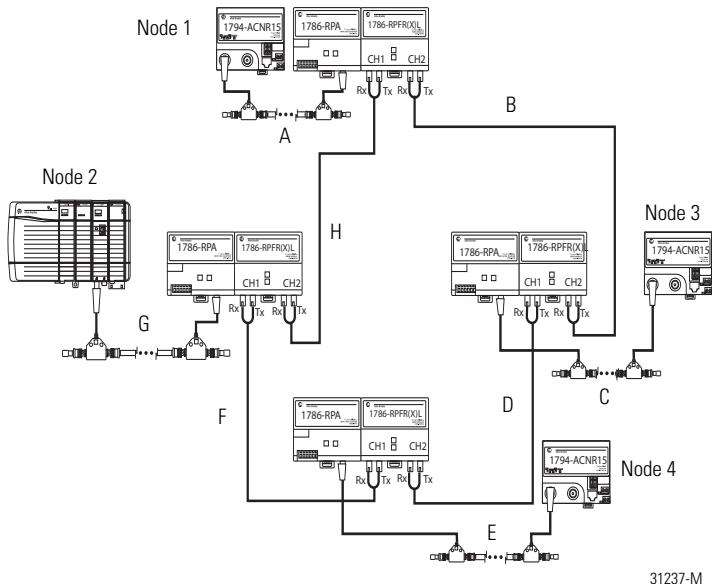

31237-M

Segment	Length
A	200 m
B	2 km
C	10 m
D	1 km
E	20 m
F	5 km
G	20 m
H	200 m

EXAMPLE Determining worst-case delay

To determine the worst-case delay in a ring topology, first disregard the shortest fiber segment in the system.

In [Figure 4](#) on [page 22](#), the shortest segment is segment H, with the 200 m fiber. Remove segment H. You will see that the worst-case delay is now between nodes 1 and 2.

You must account for worst-case delays introduced by physical media when setting up the media configuration screen in RSNetWorx software. If too many components with too great a delay are entered into RSNetWorx for ControlNet software, the delay becomes too great for the bandwidth RSNetWorx software has available. This affects system performance and limits network length. If you do not account for all media components in the worst-case delay path, erratic network operation will result. Refer to the documentation supplied with RSNetWorx for ControlNet software for more information.

This example shows you in a simple way how to account for system delays. In this example, you enter the total length of all media components between nodes 1 and 2 into RSNetWorx for ControlNet software. The totals of the components between nodes 1 and 2 are as follows, as specified in [Table 1](#) on [page 21](#):

Coax media delay: 200 m (A) + 20 m (G) = 220 m x 4.17 ns

Fiber media delay: 2 km (B) + 1 km (D) + 5 km (F) = 8 km x 5.01 ns

1786-RPA/B module delay: 1 (at node 1) + 1 (at node 3) + 1 (at node 4) + 1 (at node 2) = 4 x 901 ns

1786-RPFR/L/B or 1786-RPFRXL/B module: 1 (at node 1) + 1 (at node 3) + 1 (at node 4) + 1 (at node 2) = 4 x 100 ns

In summary:

Worst-case delay = 220 x 4.17 + 8000 x 5.01 + 4 (901) + 4 (100) = 45 μ s

This delay is acceptable because 45 μ s is less than the maximum allowable delay of 121 μ s.

Set up the Network SMAX Parameter in RSNetWorx Software

You must set up the SMAX parameter in RSNetWorx for ControlNet software to use with the 1786-RPFRL/B or 1786-RPFRXL/B module. The SMAX parameter sets the maximum scheduled node address on a ControlNet network. Refer to the documentation supplied with the RSNetWorx for ControlNet software.

You must set the SMAX parameter at least one node number higher than the highest used scheduled node number. For example, on a network with 49 scheduled nodes (with 49 being the highest used scheduled node number), you must set SMAX to at least 50. In this example, node number 50 is an unused scheduled node number.

IMPORTANT When setting the SMAX parameter, you must allow one unused scheduled node address. This unused node address must be the highest available scheduled node number. Therefore, the maximum usable node address when using the 1786-RPFRL/B or 1786-RPFRXL/B module is 98.

Connect the Cable Between the Repeater Modules

The following pages explain instructions for properly and safely connecting fiber cable.

Terminate the Cable

Termination is the process of attaching connectors to the ends of fiber cable. Follow these general instructions when terminating fiber cable.



ATTENTION: Safety glasses are required to protect your eyes when you handle chemicals and cut fiber. Pieces of glass fiber are very sharp and can easily damage the cornea of your eye.

Cleaved glass fibers are very sharp and can pierce the skin easily. Do not let cut pieces of fiber stick to your clothing or drop in the work area where they can cause injury later. Use tweezers to pick up cut or broken pieces of the glass fibers and place them on a loop of tape kept for that purpose alone. Keep your work area clean.

IMPORTANT Be certain to follow the instructions that are provided by your fiber termination kit manufacturer.

1. Organize your termination kit materials.
2. Reference your plan to be certain that you have enough supplies to make the fiber connections and to terminate all used fiber cable ends.
3. Make a schedule for performing the connections.
4. Follow the assembly and safety procedures for your termination kit.
5. Place a dust cap (supplied in fiber cable kits) on the end of the connector.



ATTENTION: If this equipment is used in a manner not specified by the manufacturer, the protection provided by the equipment may be impaired.

Connect the Cable

This section describes how to connect cables by using the tracer on the cable to identify and follow the cable throughout your system.

A tracer is one of the two wires on the duplex cable that is one of the following:

- Printed with the cable legend
- Ribbed

For further information on choosing cables and wiring your system, refer to the ControlNet Fiber Media Planning and Installation Guide, publication [CNET-IN001](#).

The instructions explain how to connect the cable between the fiber modules by making a simple ‘criss-cross’ connection. To do this, you will connect the cables between modules from the receive (RX) end of one channel to the transmit (TX) end of the other module, as shown in the following diagram.

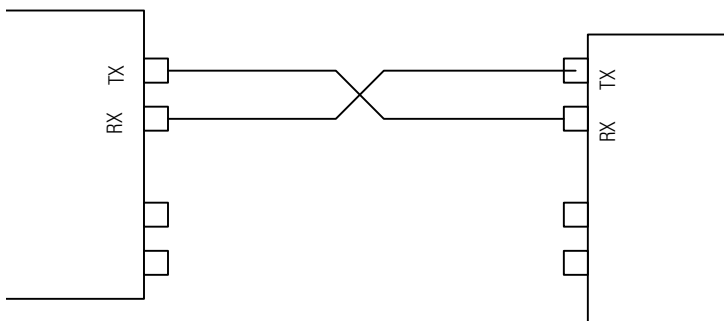

TIP Channels 1 and 2 on the module are identical. Channel 1 of a module can be connected to either channel of another module.

Do these steps to connect the cable.

1. Use the tracers on the cable to identify which cable is connected to the receive (RX) port and which one to the transmit port (TX).

2. Connect the receive port (RX) and transmit port (TX) at the starting module.
3. Do the following to attach the cable connector to the module connector.

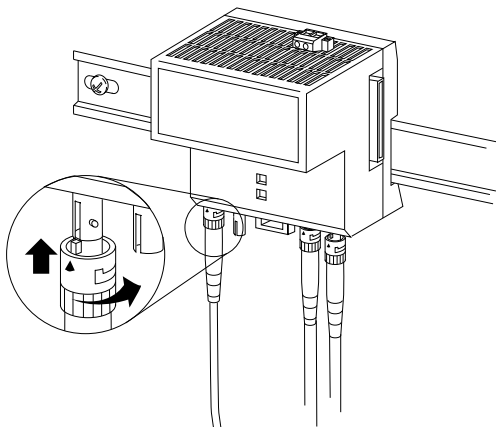

42550

- a. Align the key of the cable connector with the slot in the module connector, and insert the connector into the RX port.
 - b. Push and twist the locking cap until the bayonet lug is locked into place.
4. At the second module, connect the cables in reverse.

For example, tracer to TX port on module 1, non-tracer to RX port on module 1; tracer to RX port on module 2, non-tracer to TX port on module 2.



ATTENTION: Under certain conditions, viewing the optical port may expose the eye to hazard. When viewed under some conditions, the optical port may expose the eye beyond the maximum permissible exposure recommendations.

Interpret the Status Indicators

Fiber repeaters receive status information from the repeater adapters. Because of this, you should use the fiber repeater status indicators in conjunction with the 1786-RPA/B status indicators to diagnose an anomaly.

For status indicators for this module	See
1786-RPA/B	Table 2
1786-RPFRL/B and 1786-RPFRXL/B	Table 3

TIP In general, if the status indicators on the 1786-RPA/B module are green, the fiber repeater module is operating properly.

For more information on the 1786-RPA/B module, refer to the ControlNet Modular Repeater Adapter Installation Instructions, publication [1786-IN013](#).

1786-RPA/B Status Indicators

The status indicators on the repeater adapter can be interpreted singly or together. The following three tables list different combinations of status indicators and their interpretations.

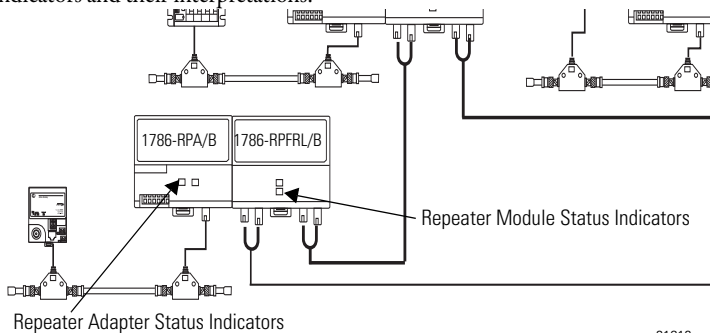

31216

Table 2 -1786-RPA/B Repeater Adapter Module Status Indicators

If repeater adapter indicator is	This means	You should
Alternating red/green	The repeater adapter is being powered or reset.	Do nothing. The repeater adapter is operating properly.
Solid red	A jabber condition has occurred. Another node or repeater on the network is transmitting constantly.	Check the network and components for proper operation.
Off	The repeater adapter is not powered or has failed.	Check the power input to the repeater adapter for correct voltage and polarity.
Solid green	Error-free data is being recovered at the coax port of the repeater adapter.	Do nothing. The repeater adapter is operating properly.
Flashing green/off	Data with errors is occasionally being recovered at the coax port of the repeater adapter.	This situation will normally correct itself. If the situation persists check the following: <ul style="list-style-type: none"> • All BNC connector pins are seated properly. • All taps are Rockwell Automation taps. • All terminators are 75 Ω and are installed at both ends. • The coax cable has not been grounded.
Flashing red/off	Either no data is being received at the coax port of the repeater adapter, or data with a large number of errors is being received at the coax port of the repeater adapter.	Check for the following: <ul style="list-style-type: none"> • Broken cables. • Broken taps. • Missing segment terminators.

1786-RPFRL/B or 1786-RPRFRXL/B Status Indicators

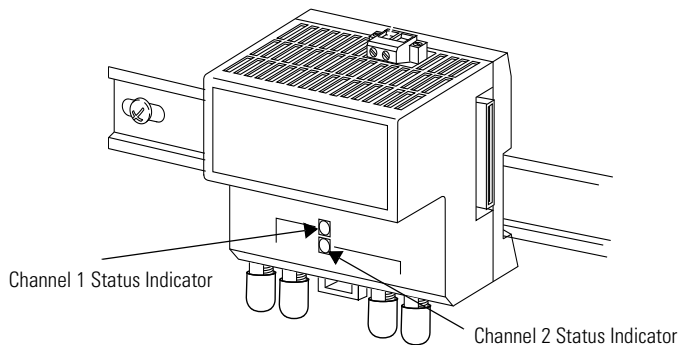

Table 3 - Fiber Repeater Module Status Indicators

If the fiber repeater module indicator is	This means	You should
Off	Fiber repeater module is not connected to the power supply.	Connect the repeater to the power supply.
Green	Fiber repeater module is running without network errors.	Do nothing. The fiber repeater module is operating properly.
Flashing green/off	No data activity on network.	If the cable is attached, do the following: <ul style="list-style-type: none"> • Ensure that the receive (RX) channel is connected to the transmit (TX) channel on both modules. • Check for broken fiber.

Table 3 - Fiber Repeater Module Status Indicators

If the fiber repeater module indicator is	This means	You should
Flashing red/off	Module is powered, but not ready for operation. This state should also occur during module reset and last for approximately 5 seconds.	Do nothing. The fiber repeater module is operating properly.
Intermittent red	As more data errors are detected the frequency of the flashing red increases until a solid red displays.	Check for proper operation.
Red	Excessive receive signal distortion.	Review these items: <ul style="list-style-type: none"> • Be certain that you are using the correct fiber type for your module. • Check fiber length and attenuation to make sure that it is within specification. • Replace the downstream 1786-RPFRL module on the channel that is having the intermittently flashing red status indicator. • Be certain that your total network length is not out of specification. • Be certain that SMAX is correctly defined in the RSNetWorx for ControlNet software.

1786-RPFRL/B or 1786-RPFRXL/B Relay Contact Connector

The fiber repeater module contains a single electromechanical relay for communication and system status.

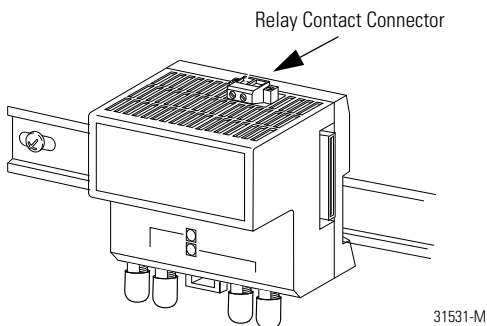

Table 4 -Relay Contact Connector Diagnostics

If	Then
<ul style="list-style-type: none"> • No receive data is present at one or both fiber-optic ports for more than 1300 ms (that means if either Channel 1 or Channel 2 status indicators are not solid green, the fault relay will open.) • The repeater is not connected to the power supply. 	The relay contact is open.
Neither of the above two conditions are met.	The relay contact is closed.

Specifications

Technical Specifications - 1786-RPFRL/B, 1786-RPFRXL/B

Attribute	1786-RPFRL/B, 1786-RPFRXL/B
All supply voltages or voltage ranges	Input: 570 mA @ 5V DC, max Relay: 900 mA @ 30V DC, max resistive
Backplane power requirements	2.8 W (3.02 W, max) ⁽¹⁾
Communication rate	5 Mbps
Mounting orientation	Any mounting orientation
Relay contact connector voltage	30V DC, max
Relay contact connector current consumption	1 mA, min; 900 mA, max
Relay contact load type	Resistive only
Isolation voltage	50V (continuous), Basic insulation type, Relay contacts to system
Optical power budget	See the optical power budget table on page 19
Wire size	0.25... 2.5 mm ² (22...14 AWG) solid or stranded copper wire rated at 75 °C (167 °F), or greater, 1.2 mm (3/64 in.) insulation max for relay connections
Wiring category	2 - on signal ports ⁽²⁾
Enclosure type rating	None (open-style)
North American temp code	T5

- (1) Operational power is provided from the 1786-RPA/B module. For application within the U.S., supply the 1786-RPA/B module from a power supply that is appropriately certified Class 2 per the definition in the National Electrical Code, ANSI/NFPA 70, Article 725. For applications outside the U.S., supply the 1786-RPA/B module from a safety extra low voltage (SELV) power supply. SELV output is built with appropriate isolation to withstand single fault conditions. The output cannot exceed 30V rms, 42.4V peak, or 60V DC under fault conditions.
- (2) Use this Conductor Category information for planning conductor routing. Refer to Industrial Automation Wiring and Grounding Guidelines, publication [1770-4.1](#).

Environmental Specifications - 1786-RPFRL/B, 1786-RPFRXL/B

Attribute	1786-RPFRL/B, 1786-RPFRXL/B
Temperature, operating IEC 60068-2-1 (Test Ad, Operating Cold), IEC 60068-2-2 (Test Bd, Operating Dry Heat), IEC 60068-2-14 (Test Nb, Operating Thermal Shock)	0...60 °C (32...140 °F)
Temperature, surrounding air, max	60 °C (140 °F)
Temperature, nonoperating IEC 60068-2-1 (Test Ab, Unpackaged Nonoperating Cold), IEC 60068-2-2 (Test Bb, Unpackaged Nonoperating Dry Heat), IEC 60068-2-14 (Test Na, Unpackaged Nonoperating Thermal Shock)	-40...85 °C (-40...185 °F)
Relative humidity IEC 60068-2-30 (Test Db, Unpackaged Damp Heat)	5...95% noncondensing
Vibration IEC60068-2-6 (Test Fc, Operating)	5 g @ 10...500 Hz
Shock, operating IEC60068-2-27 (Test Ea, Unpackaged Shock)	30 g
Shock, nonoperating IEC60068-2-27 (Test Ea, Unpackaged Shock)	50 g
Emissions CISPR 11	Group 1, Class A
ESD immunity IEC 61000-4-2	6 kV contact discharges 8 kV air discharges

Environmental Specifications - 1786-RPFRL/B, 1786-RPFRXL/B

Attribute	1786-RPFRL/B, 1786-RPFRXL/B
Radiated RF immunity IEC 61000-4-3	10V/m with 1 kHz sine-wave 80% AM from 80...2000 MHz 10V/m with 200 Hz 50% Pulse 100% AM at 900 and 1890 MHz 1V/m with 1 kHz sine-wave 80% AM from 2000...2700 MHz
EFT/B immunity IEC 61000-4-4	±4 kV at 5 kHz on signal ports
Surge transient immunity IEC 61000-4-5	±1 kV line-line (DM) and ±2 kV line-earth (CM) on signal ports
Conducted RF Immunity IEC 61000-4-6	10V rms with 1 kHz sine-wave 80% AM from 150 kHz...80 MHz

Certifications⁽¹⁾ - 1786-RPFRL/B, 1786-RPFRXL/B

Certification ⁽²⁾	1786-RPFRL/B, 1786-RPFRXL/B
c-UL-us ⁽³⁾	UL Listed for Class I, Division 2 Group A,B,C,D Hazardous Locations, certified for U.S. and Canada. See UL File E194810.
CE ⁽⁴⁾	European Union 2004/108/EC EMC Directive, compliant with: <ul style="list-style-type: none"> • EN 61326-1; Meas./Control/Lab., Industrial Requirements • EN 61000-6-2; Industrial Immunity • EN 61000-6-4; Industrial Emissions • EN 61131-2; Programmable Controllers (Clause 8, Zone A & B)
C-Tick	Australian Radiocommunications Act, compliant with: <ul style="list-style-type: none"> • AS/NZS CISPR 11; Industrial Emissions

(1) When product is marked.

(2) See the Product Certification link at <http://www.ab.com> for Declarations of Conformity, Certificates, and other certification details.

(3) To comply with UL restrictions, the relay connection must be powered from a source compliant with Class 2 or Limited Voltage/Current.

(4) To comply with the CE Low Voltage Directive (LVD), the relay connection must be powered from a source compliant with safety extra low voltage (SELV) or protected extra low voltage (PELV).

Additional Resources

These documents contain additional information concerning related Rockwell Automation products.

Resource	Description
ControlNet Coax Taps Installation Instructions, publication 1786-IN007	Document contains procedures and specifications for the installation of ControlNet coaxial taps.
ControlNet Coax Media Planning and Installation Guide, publication CNET-IN002	Document describes the components and topologies for creating a ControlNet coax media system.
ControlNet Fiber Media Planning and Installation Guide, publication CNET-IN001	Document describes the components and topologies for creating a ControlNet fiber media system.
Industrial Automation Wiring and Grounding Guidelines, publication 1770-4.1	Document contains more information on proper wiring and grounding techniques.

You can view or download publications at <http://www.rockwellautomation.com/literature/>. To order paper copies of technical documentation, contact your local Rockwell Automation distributor or sales representative.

Notes:

Notes:

Rockwell Automation Support

Rockwell Automation provides technical information on the Web to assist you in using its products. At <http://www.rockwellautomation.com/support/>, you can find technical manuals, a knowledge base of FAQs, technical and application notes, sample code and links to software service packs, and a MySupport feature that you can customize to make the best use of these tools.

For an additional level of technical phone support for installation, configuration, and troubleshooting, we offer TechConnect support programs. For more information, contact your local distributor or Rockwell Automation representative, or visit <http://www.rockwellautomation.com/support/>.

Installation Assistance

If you experience a problem within the first 24 hours of installation, please review the information that's contained in this manual. You can also contact a special Customer Support number for initial help in getting your product up and running.

United States or Canada	1.440.646.3434
Outside United States or Canada	Use the Worldwide Locator at http://www.rockwellautomation.com/support/americas/phone_en.html , or contact your local Rockwell Automation representative.

New Product Satisfaction Return

Rockwell Automation tests all of its products to ensure that they are fully operational when shipped from the manufacturing facility. However, if your product is not functioning and needs to be returned, follow these procedures.

United States	Contact your distributor. You must provide a Customer Support case number (call the phone number above to obtain one) to your distributor to complete the return process.
Outside United States	Please contact your local Rockwell Automation representative for the return procedure.

Documentation Feedback

Your comments will help us serve your documentation needs better. If you have any suggestions on how to improve this document, complete this form, publication [RA-DU002](#), available at <http://www.rockwellautomation.com/literature/>.

Allen-Bradley, Rockwell Software, Rockwell Automation, RSNetWorx for ControlNet, RSNetWorx, and TechConnect are trademarks of Rockwell Automation, Inc.

Trademarks not belonging to Rockwell Automation are property of their respective companies.

Rockwell Otomasyon Ticaret A.Ş., Kar Plaza İş Merkezi E Blok Kat:6 34752 İçerenköy, İstanbul, Tel: +90 (216) 5698400

www.rockwellautomation.com

Power, Control and Information Solutions Headquarters

Americas: Rockwell Automation, 1201 South Second Street, Milwaukee, WI 53204-2496 USA, Tel: (1) 414.382.2000, Fax: (1) 414.382.4444
Europe/Middle East/Africa: Rockwell Automation NV, Pegasus Park, De Kleetlaan 12a, 1831 Diegem, Belgium, Tel: (32) 2 663 0600, Fax: (32) 2 663 0640
Asia Pacific: Rockwell Automation, Level 14, Core F, Cyberport 3, 100 Cyberport Road, Hong Kong, Tel: (852) 2887 4788, Fax: (852) 2508 1846

Publication 1786-IN003D-EN-P - April 2011

PN-92666

Supersedes Publication 1786-IN003C-EN-P - February 2002

Copyright © 2011 Rockwell Automation, Inc. All rights reserved. Printed in the U.S.A.