

PowerFlex 700 Adjustable Frequency AC Drive – Frames 0...6

0.37...132 kW (0.5...200 Hp)

This document explains the 5 BASIC STEPS needed to install and perform a Basic Start-Up of the PowerFlex 700 (Series A or B) AC drive. A Human Interface Module (HIM) is required to perform the Basic Start-Up routine covered in this manual.

The information provided is intended for qualified installers only.

Additional Resources

These documents contain additional information concerning related products from Rockwell Automation.

Resource	Description
PowerFlex 700 Standard Control User Manual, publication 20B-UM001	Provides detailed information on: <ul style="list-style-type: none"> Parameters and programming Faults, alarms, and troubleshooting
PowerFlex 700 Vector Control User Manual (v4.001 & up), publication 20B-UM002	
PowerFlex 700 AC Drive Technical Data, publication 20B-TD001	This publication provides detailed drive specifications, option specifications and input protection device ratings.
PowerFlex Comm Adapter Manuals, publication 20COMM-UM...	These publications provide information on configuring, using, and troubleshooting PowerFlex communication adapters.
PowerFlex 70 and PowerFlex 700 Reference Manual, publication PFLEX-RM001	These publications provide detailed application specific information for programming and configuring the PowerFlex 700 drive.
PowerFlex 70 Enhanced Control and PowerFlex 700 Vector Control Reference Manual, publication PFLEX-RM004	
Wiring and Grounding Guidelines for Pulse Width Modulated (PWM) AC Drives, publication DRIVES-IN001	Provides basic information needed to properly wire and ground PWM AC drives.
Safety Guidelines for the Application, Installation and Maintenance of Solid State Control, publication SGI-1.1	Provides general guidelines for the application, installation, and maintenance of solid-state control.
Guarding Against Electrostatic Damage, publication 8000-4.5.2	Provides practices for guarding against Electrostatic damage (ESD)
Product Certifications website, http://ab.com	Provides declarations of conformity, certificates, and other certification details.

You can view or download publications at <http://www.rockwellautomation.com/literature/>. To order paper copies of technical documentation, contact your local Allen-Bradley distributor or Rockwell Automation sales representative.

Allen-Bradley Drives Technical Support

Use the contacts below for PowerFlex 700 technical support including spare parts information.

Online at...	By Email at...	By Telephone at...
www.ab.com/support/abdrives	support@drives.ra.rockwell.com	262-512-8176

Installation Instructions in Other Languages

English	This instruction sheet is available in multiple languages at http://www.rockwellautomation.com/literature . Select publication language and type "20B-IN019" in the search field.
Deutsch	Dieses Instruktionsblatt kann in mehreren Sprachen unter http://www.rockwellautomation.com/literature gelesen werden. Bitte Ihre Sprache anwählen und "20B-IN019" im Suchfeld eintippen.
Français	Ces instructions sont disponibles dans différentes langues à l'adresse suivante: http://www.rockwellautomation.com/literature . Sélectionner la langue puis taper << 20B-IN019 >> dans le champ de recherche.
Italiano	La presente scheda d'istruzione è disponibile in varie lingue sul sito http://www.rockwellautomation.com/literature . Selezionare la lingua desiderata e digitare "20B-IN019" nel campo di ricerca.
Español	Puede encontrar esta hoja de instrucciones en varios idiomas en http://www.rockwellautomation.com/literature . Seleccione el idioma de publicación y escriba "20B-IN019" en el campo de búsqueda.
Português	Esta folha de instruções está disponível em várias línguas em http://www.rockwellautomation.com/literature . Selecione a língua de publicação e entre com "20B-IN019" no espaço de busca.
Chinese (simplified)	从以下网页可以获得本说明书的多种语言的版本： http://www.rockwellautomation.com/literature? 请选择出版物的语言，并在搜索栏输入“20B-IN019 印？”

Table of Contents

Catalog Number Explanation	4
Step 1: Read the Precautions and General Information	5
EMC Instructions	7
Step 2: Mount the Drive	9
Accessing the Terminals	9
Environment	9
Minimum Mounting Clearances	10
Dimensions	11
Step 3: Wire the Drive – Power	21
Special Considerations	21
Cable Types Acceptable for 200...600 Volt Installations	22
Single-Phase Input Power	24
Selecting/Verifying Fan Voltage (Frames 5...6 Only)	26
Auxiliary Control Power Supply	27
Power Terminal Blocks	28
Power and Ground Wiring	31
Motor Overload Protection	32
Drive, Fuse & Circuit Breaker Ratings	33
Output Devices	41
Using Input/Output Contactors	42
Disconnecting MOVs and Common Mode Capacitors	43
Step 4: I/O Wiring	52
I/O Terminals	53
I/O Wiring Examples	56
Hardware Enable Circuitry (Vector Control Only)	57
Encoder Interface Option (Vector Control Only)	58
Reference Control	59
Step 5: Start-Up Check List	62
Prepare For Drive Start-Up	62
Supplemental Information	65
Using PowerFlex Drives w/Regen Units	65
DC Input (Common Bus) and Precharge Notes	65
Human Interface Module (HIM) Overview	66
Start-Up Routines	67
Drive Status Indicators	70
Common I/O Programming Changes	71
Troubleshooting	72
Common Symptoms and Corrective Actions	74
Manually Clearing Faults	76

Catalog Number Explanation

20B **D** 2P1 **A** 3 **A** **Y** **N** **A** **E** **C** 0 **NN** **AD**
a *b* *c* *d* *e* *f* *g* *h* *i* *j* *k* *l* *m* *n*

a

Drive	
Code	Type
20B	PowerFlex 700

b

Voltage Rating				
Code	Voltage	Ph.	Prechg.	Frames
B	240V AC	3	-	0...6
C	400V AC	3	-	0...6
D	480V AC	3	-	0...6
E	600V AC	3	-	0...6
F	690V AC	3	-	5...6
H	540V DC	-	N	5...6
J	650V DC	-	N	5...6
N	325V DC	-	Y	5...6
P	540V DC	-	Y	5...6
R	650V DC	-	Y	5...6
T	810V DC	-	Y	5...6
W	932V DC	-	Y	5...6

c

ND Output Rating		
Example		
Code	Amps	kW (Hp)
2P2	2.2	0.37 (0.5)
022	22	5.5 (7.5)

d

Enclosure	
Code	Enclosure
A	IP20, NEMA/UL Type 1
F †	Open/Flange Mount Front: IP00, NEMA/UL Type Open Back/Heatsink: IP54, NEMA Type 12
G †	Stand-Alone/Wall Mount IP54, NEMA/UL Type 12

† Only available for Frame 5 & Frame 6 drives, 400...690V.

e

HIM	
Code	Operator Interface
0	Blank Cover
3	LCD Display, Full Numeric Keypad
J †	Remote (Panel Mount), IP66, NEMA/UL Type 12 Full Numeric LCD HIM
K †	Remote (Panel Mount), IP66, NEMA/UL Type 12 Prog. Only LCD HIM

† Available with Frames 5...6 Stand-Alone IP54 drives (Enclosure Code "G").

f

Documentation	
Code	Type
A	Manual
N	No Manual
Q	No Shipping Package (Internal Use Only)

g

Brake	
Code	w/Brake IGBT ‡
Y	Yes
N	No

‡ Brake IGBT is standard on Frames 0-3, optional on Frames 4-6.

h

Internal Braking Resistor	
Code	w/Resistor
Y	Yes *
N	No

* Not available for Frame 3 drives or larger.

i

Emission		
Code	CE Filter §	CM Choke
A	Yes	Yes
B #	Yes	No
N	No	No

§ Note: 600V class drives below 77 Amps (Frames 0-4) are declared to meet the Low Voltage Directive. It is the responsibility of the user to determine compliance to the EMC directive.

Only available for 208...240V Frame 0-3 drives.

j

Comm Slot	
Code	Network Type
C	ControlNet (Coax)
D	DeviceNet
E	EtherNet/IP
N	None

k

Control & I/O		
Code	Control	I/O Volts
A	Standard	24V DC/AC
B	Standard	115V AC
C	Vector Δ	24V DC
D	Vector Δ	115V AC
N	Standard	None

Δ Vector Control Option utilizes DPI Only.

l

Feedback	
Code	Type
0	None
1	Encoder, 12V/5V

m

Future Use

n

Special Firmware (Frames 0...6 Only)	
Code	Type
AD †	60 Hz Maximum
AE †	Cascading Fan/Pump Control
AX †	82 Hz Maximum
BA †	Pump Off (for pump jack)

† Must be used with Vector Control option C or D (Position k). Positions m-n are only required when custom firmware is supplied.

Step 1: Read the Precautions and General Information

Qualified Personnel



ATTENTION: Only qualified personnel familiar with adjustable frequency AC drives and associated machinery must plan or implement the installation, start-up and subsequent maintenance of the system. Failure to comply can result in personal injury and/or equipment damage.

Personal Safety



ATTENTION: To avoid an electric shock hazard, verify that the voltage on the bus capacitors has discharged before performing any work on the drive. Measure the DC bus voltage at the following points (refer to pages [28](#) through [30](#) for locations):

- +DC and -DC terminals of the Power Terminal Block
- +DC terminal of the Power Terminal Block and the chassis
- -DC terminal of the Power Terminal Block and the chassis

The voltage must be zero for all three measurements.



ATTENTION: Risk of injury or equipment damage exists. DPI or SCANport host products must not be directly connected together via 1202 cables. Unpredictable behavior can result if two or more devices are connected in this manner.



ATTENTION: The drive start/stop/enable control circuitry includes solid state components. If hazards due to accidental contact with moving machinery or unintentional flow of liquid, gas or solids exist, an additional hardwired stop circuit can be required to remove the AC line to the drive. An auxiliary braking method can be required.



ATTENTION: Loss of control in suspended load applications can cause personal injury and/or equipment damage. Loads must always be controlled by the drive or a mechanical brake. Parameters 600...611 are designed for lifting/torque proving applications. It is the responsibility of the engineer and/or end user to configure drive parameters, test any lifting functionality and meet safety requirements in accordance with all applicable codes and standards.

Product Safety



ATTENTION: An incorrectly applied or installed drive can result in component damage or a reduction in product life. Wiring or application errors, such as, undersizing the motor, incorrect or inadequate AC supply, or excessive ambient temperatures can result in malfunction of the system.



ATTENTION: This drive contains ESD (Electrostatic Discharge) sensitive parts and assemblies. Static control precautions are required when installing, testing, servicing or repairing this assembly. Component damage can result if ESD control procedures are not followed. If you are not familiar with static control procedures, reference Guarding Against Electrostatic Damage, publication 8000-4.5.2 or any other applicable ESD protection handbook.



ATTENTION: The “adjust freq” portion of the bus regulator function is extremely useful for preventing nuisance overvoltage faults resulting from aggressive decelerations, overhauling loads, and eccentric loads. It forces the output frequency to be greater than commanded frequency, while the bus voltage is increasing toward a level that causes a fault. However, it can also cause either of the following two conditions to occur.

- Fast positive changes in input voltage (more than a 10% increase within 6 minutes) can cause uncommanded positive speed changes. However an “OverSpeed Limit” fault (F25) occurs if the speed reaches [Maximum Speed] + [Overspeed Limit], (parameters 82 and 83). If this condition is unacceptable, action must be taken to 1) limit supply voltages within the specification of the drive and, 2) limit fast positive input voltage changes to less than 10%. Without taking such actions, if this operation is unacceptable, the “adjust freq” portion of the bus regulator function must be disabled (see parameters 161 and 162).
- Actual deceleration times can be longer than commanded deceleration times. However, a “Decel Inhibit” fault (F24) is generated if the drive stops decelerating altogether. If this condition is unacceptable, the “adjust freq” portion of the bus regulator must be disabled (see parameters 161 and 162). In addition, installing a properly sized dynamic brake resistor provides equal or better performance in most cases.

Important: These faults are not instantaneous. Test results have shown that they can take between 2...12 seconds to occur.

EMC Instructions

CE Conformity

Conformity with the Low Voltage (LV) Directive and Electromagnetic Compatibility (EMC) Directive has been demonstrated by using harmonized European Norm (EN) standards published in the Official Journal of the European Communities. PowerFlex Drives⁽¹⁾ comply with the EN standards listed below when installed according to the information supplied in this publication and the Wiring & Grounding Guidelines Manual.

CE Declarations of Conformity are available online at:

<http://www.rockwellautomation.com/rockwellautomation/certification>.

Low Voltage Directive (73/23/EEC)

- EN50178 Electronic equipment for use in power installations.

EMC Directive (89/336/EEC)

- EN61800-3 Adjustable speed electrical power drive systems Part 3: EMC product standard including specific test methods.

General Notes

- Some drives are equipped with an adhesive label on the top of the drive. If the adhesive label is removed from the top of the drive, the drive must be installed in an enclosure with side openings less than 12.5 mm (0.5 in.) and top openings less than 1.0 mm (0.04 in.) to maintain compliance with the LV Directive.
- The motor cable must be kept as short as possible to avoid electromagnetic emission as well as capacitive currents.
- Use of line filters in ungrounded systems is not recommended.
- PowerFlex drives can cause radio frequency interference if used in a residential or domestic environment. The installer is required to take measures to prevent interference, in addition to the essential requirements for CE compliance listed below, if necessary.
- Conformity of the drive with CE EMC requirements does not guarantee an entire machine or installation complies with CE EMC requirements. Many factors can influence total machine/installation compliance.
- PowerFlex drives can generate conducted low frequency disturbances (harmonic emissions) on the AC supply system.
- When operated on a public supply system, it is the responsibility of the installer or user to ensure, by consultation with the distribution network operator and Rockwell Automation, if necessary, that applicable requirements have been met.

(1) 600V class drives below 77A (Frames 0...4) are declared to meet the essential requirements of the Low Voltage Directive. It is the responsibility of the user to determine compliance to the EMC directive.

Essential Requirements for CE Compliance

Conditions 1...6 listed below **must be** satisfied for PowerFlex drives to meet the requirements of **EN61800-3**.

1. Standard PowerFlex 700 CE compatible Drive.
2. Review important precautions/attention statements throughout this publication and the User Manual before installing the drive.
3. Grounding as described in this publication and the User Manual.
4. Output power, control (I/O) and signal wiring must be braided, shielded cable with a coverage of 75% or better, metal conduit, or equivalent attenuation.
5. All shielded cables must terminate with the proper shielded connector.
6. The following conditions:
 - First Environment Restricted Distribution - For any drive and option a filter is required for motor cable lengths greater than 150 m (492 ft.).
 - Second Environment (Industrial) - Motor cable is limited to 30 m (98 ft.) for installations without additional external line filters.

External filters for First Environment installations and increasing motor cable lengths in Second Environment installations are available. Roxburgh models KMFA (RF3 for UL installations) and MIF or Schaffner FN3258 and FN258 models are recommended. Refer to [Table 1](#) and <http://www.dem-uk.com> and <http://www.mtec corp.com> (USA) or <http://www.schaffner.com>, respectively.

Table 1 - PowerFlex 700 Recommended Filters

Manufacturer	Frame	Manufacturer Part No.	Class A (Meters)	Class B (Meters)
Deltron	0	MIF316	—	150
		KMF318A	—	100
	1	KMF325A	—	150
	2	KMF350A	200	150
	2 without DC Common Mode Capacitor	KMF350A	176	150
	3	KMF370A	150	100
	3 without DC Common Mode Capacitor	KMF370A	150	100
Schaffner	0	FN358-16-45	—	
	1	FN358-30-47	—	
	2	FN358-42-47	50	
	2 without DC Common Mode Capacitor	FN358-42-47	150	
	3	FN358-75-52	100	
	3 without DC Common Mode Capacitor	FN358-75-52	150	

Step 2: Mount the Drive

Accessing the Terminals

Opening the Cover



Frames 0...4

Locate the slot in the upper left corner. Slide the locking tab up and swing the cover open. Special hinges allow cover to move away from drive and lay on top of adjacent drive (if present). See below for frame 4 access panel removal.

Frame 5

Slide the locking tab up, loosen the right-hand cover screw and remove. See below for access panel removal.

Frame 6

Loosen 2 screws at bottom of drive cover. Carefully slide bottom cover down & out. Loosen the 2 screws at top of cover and remove.

Cable Entry Plate Removal

If additional wiring access is needed, the Cable Entry Plate on 0...3 Frame drives can be removed. Simply loosen the screws securing the plate to the chassis. The slotted mounting holes assure easy removal.

IMPORTANT Removing the Cable Entry Plate limits the maximum ambient temperature to 40 °C (104 °F).

Power Wiring Access Panel Removal

Frame	Removal Procedure (Replace when wiring is complete)
0, 1, 2 & 6	Part of front cover, see above.
3	Open front cover and gently tap/slide cover down and out.
4	Loosen the 4 screws and remove.
5	Remove front cover (see above), gently tap/slide panel up and out.

Environment

Operating Temperatures

PowerFlex 700 drives are designed to operate at 0 to 40 °C ambient. To operate the drive in installations between 41 and 50 °C (106...122 °F), see [Table 2](#) and refer to pages [34](#) through [41](#) for exceptions.

Table 2 - Acceptable Surrounding Air Temperature & Required Actions

Enclosure Rating	Temperature Range	Drive
IP20, NEMA/UL Type 1 (with Top Label) ⁽¹⁾	0...40 °C (0...104 °F)	Frames 0...4, All Ratings
	0...50 °C (0...122 °F)	Frames 5...6, Most Ratings ⁽²⁾
IP20, NEMA/UL Type Open (Top Label Removed) ⁽¹⁾	0...50 °C (0...122 °F)	Frames 0...6, Most Ratings ⁽²⁾
	0...45 °C (0...113 °F)	20BC072 Only
IP00, NEMA/UL Type Open (Top Label & Vent Plate Removed)	0...50 °C (0...122 °F)	20BC072 Only ⁽³⁾
Flange Mount Front: IP00, NEMA/UL Type Open Back/Heat Sink: IP54, NEMA/UL Type 12	0...55 °C (0...131 °F) Front (Inside Encl.) 0...40 °C (0...104 °F) Back (External)	Frames 5...6
Stand-alone/Wall Mount IP54, NEMA/UL Type 12	0...40 °C (0...104 °F)	Frames 5...6

- (1) Removing the adhesive top label from the drive changes the NEMA/UL enclosure rating from Type 1 to Open. Frames 5 and 6 do not have a top label.
- (2) Refer to pages 34 through 41 for exceptions.
- (3) To remove vent plate (see page 11 for location), lift top edge of plate from the chassis. Rotate the plate out from the back plate.

Minimum Mounting Clearances

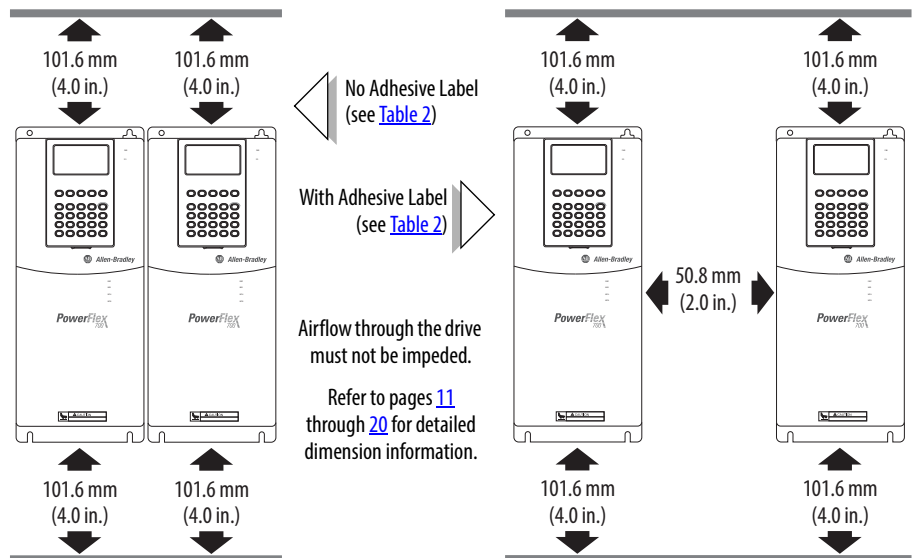

Specified vertical clearance requirements (indicated above) are intended to be from the drive to the closest object that can restrict airflow through the drive heat sink and chassis. The drive must be mounted in a vertical orientation as shown and must make full contact with the mounting surface. Do not use standoffs or spacers. In addition, inlet air temperature must not exceed the product specification.

Dimensions

Frames 0...3 – IP20, NEMA/UL Type 1

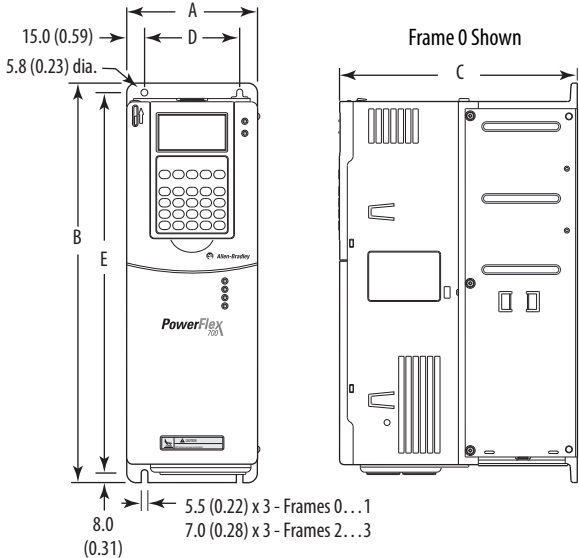

Frame	A	B	C	D	E	Weight ⁽¹⁾ kg (lbs.)	
						Drive	Drive & Packaging
0	110.0 (4.33)	336.0 (13.23)	200.0 (7.87)	80.0 (3.15)	320.0 (12.60)	5.22 (11.5)	8.16 (18)
1	135.0 (5.31)	336.0 (13.23)	200.0 (7.87)	105.0 (4.13)	320.0 (12.60)	7.03 (15.5)	9.98 (22)
2	222.0 (8.74)	342.5 (13.48)	200.0 (7.87)	192.0 (7.56)	320.0 (12.60)	12.52 (27.6)	15.20 (33.5)
3	222.0 (8.74)	517.5 (20.37)	200.0 (7.87)	192.0 (7.56)	495.0 (19.49)	18.55 (40.9)	22.68 (50)

(1) Weights include HIM and Standard I/O.

Dimensions are in millimeters and (inches)

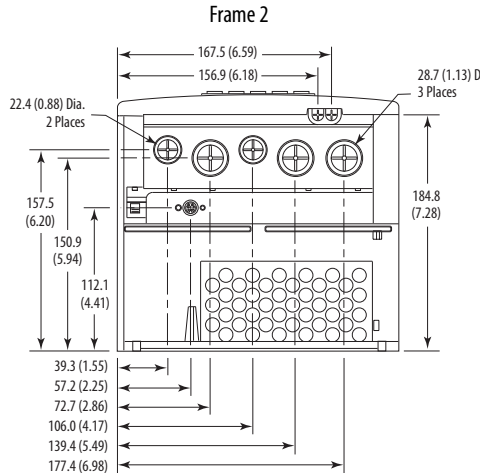
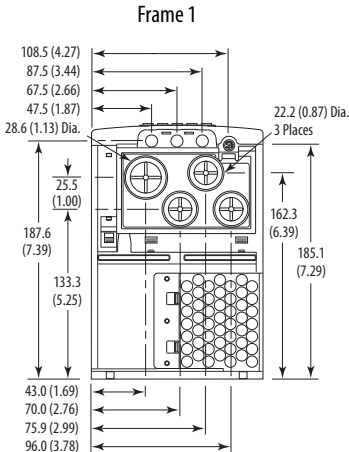
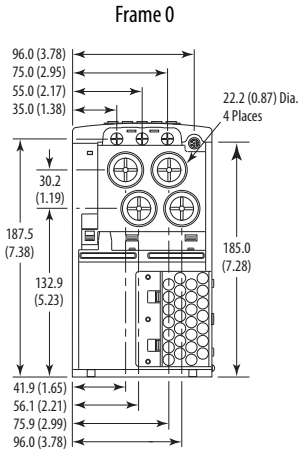

Frame 3
All except 50 Hp, 480V (37 kW, 400V)

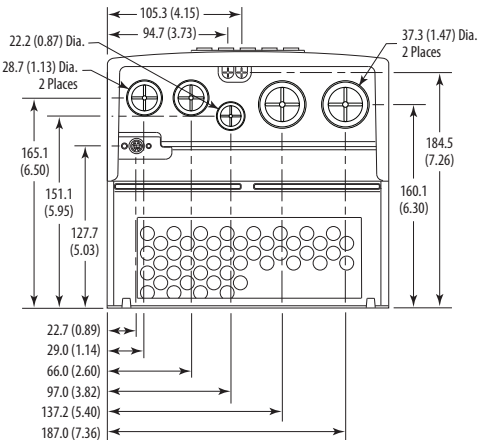

Frame 3
50 Hp, 480V (37 kW, 400V) Normal Duty Drive

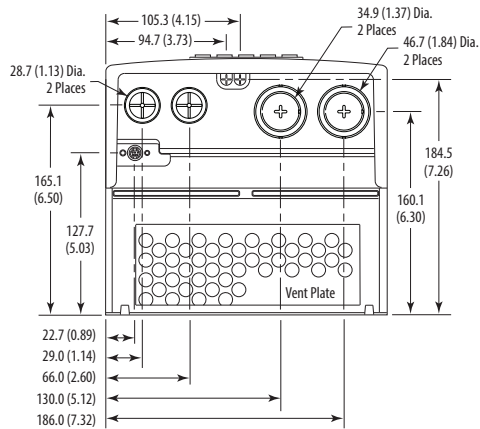

Frame 4 – IP20, NEMA/UL Type 1

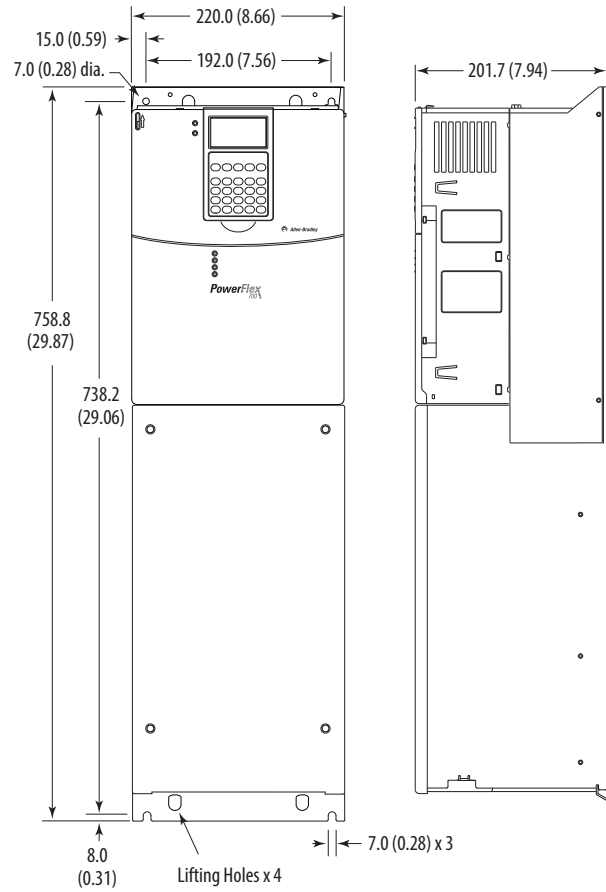

Dimensions are in millimeters and (inches)

Frame	Approx. Weight ⁽¹⁾ kg (lbs.)	
	Drive	Drive & Packaging
4	24.49 (54.0)	29.03 (64.0)

(1) Weights include HIM and Standard I/O.

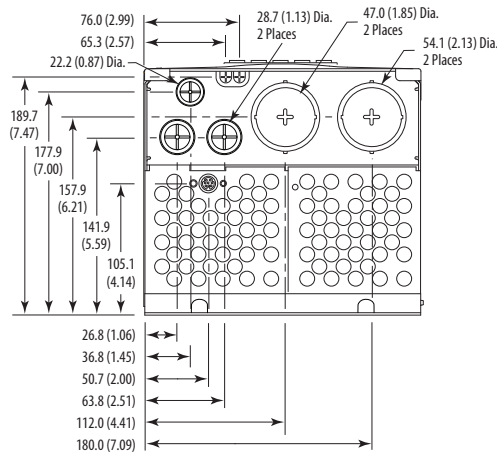

Frame 5 – IP20, NEMA/UL Type 1

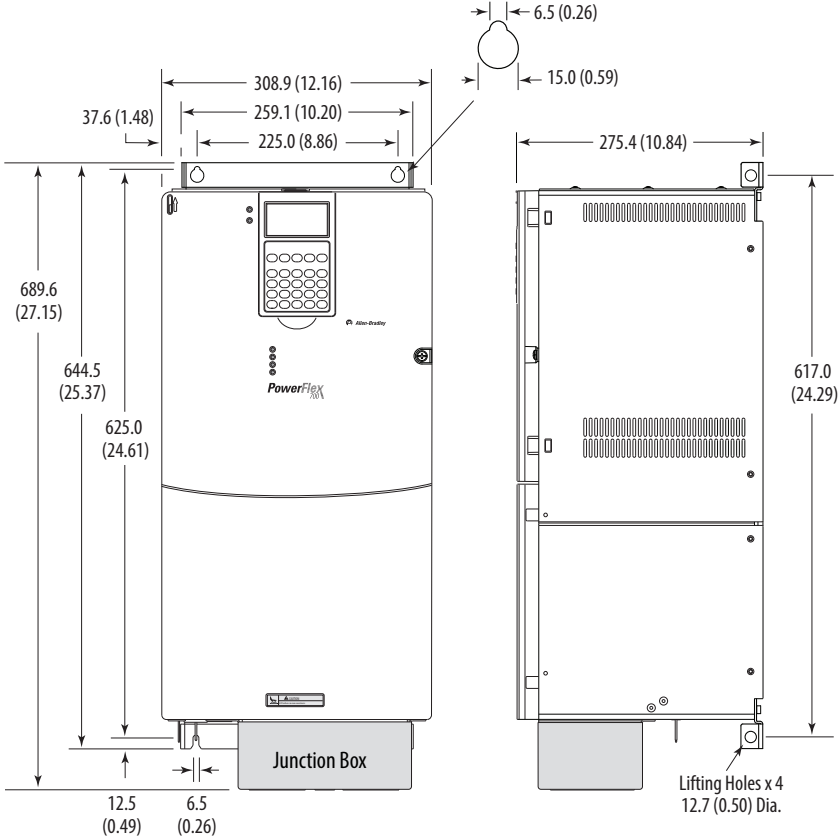

Dimensions are in millimeters and (inches)

Frame	Approx. Weight ⁽¹⁾ kg (lbs.)	
	Drive	Drive & Packaging
5	37.19 (82.0)	49.50 (109.0)

(1) Weights include HIM and Standard I/O. Add 2.70 kg (6.0 lbs.) for the 20BC140 drive.

30 kW, 208V (40 Hp, 240V)
 55 kW, 400V (75 Hp, 480V)
 45/55/75 kW, 690V (75 Hp, 600V)

37 kW, 208V (50 Hp, 240V)
 75 kW, 400V (100 Hp, 480V)
 90kW, 690V (100 Hp, 600V)

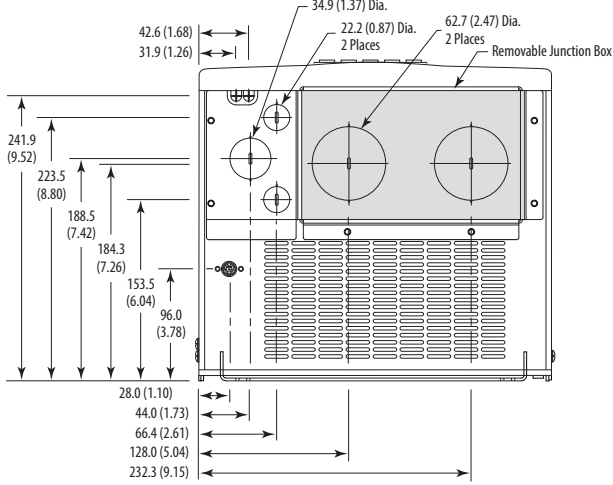
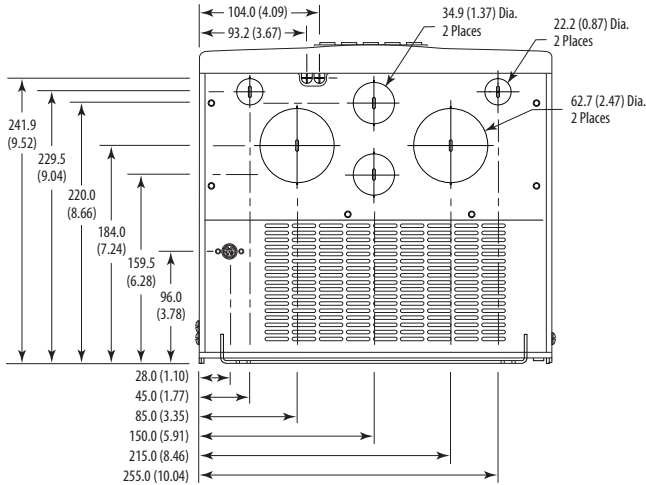

Frame 5 – IP54, NEMA Type 12 Standalone (400...690V drives only)

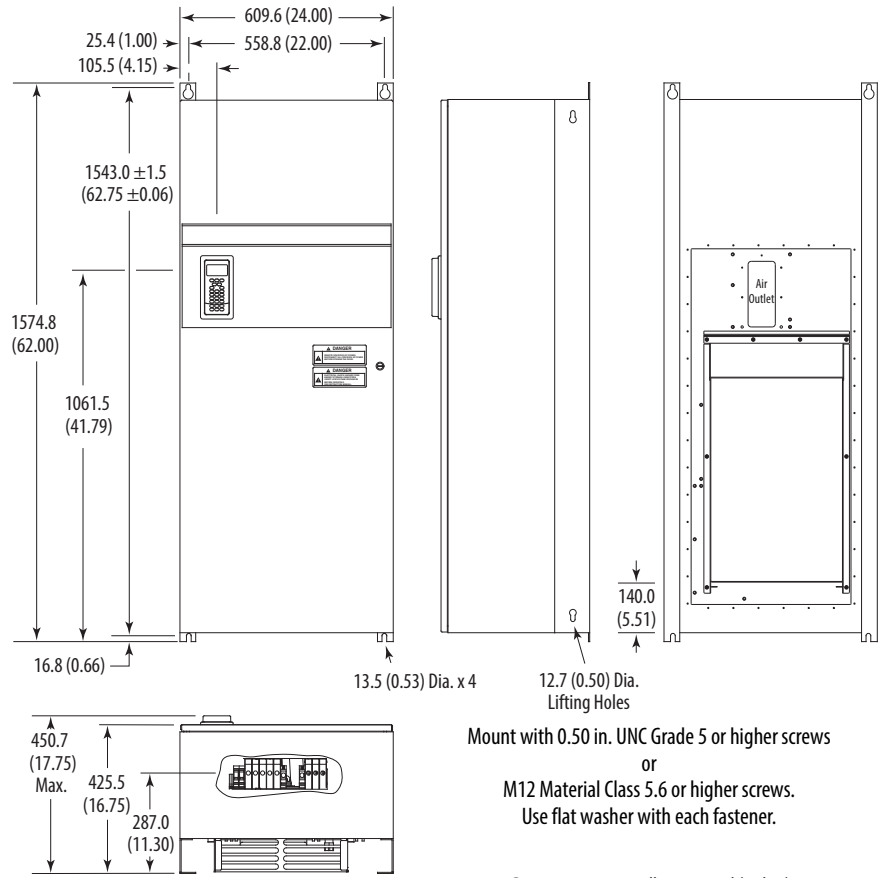

Frame	Description	Approx. Weight ⁽¹⁾ kg (lbs.)	
		Drive	Drive & Packaging
5	Standalone	102.51 (226.0)	154.68 (341.0)

(1) Weights include HIM and Standard I/O.

Frame 5 – IP54, NEMA Type 12 Flange Mount (400...690V drives only)

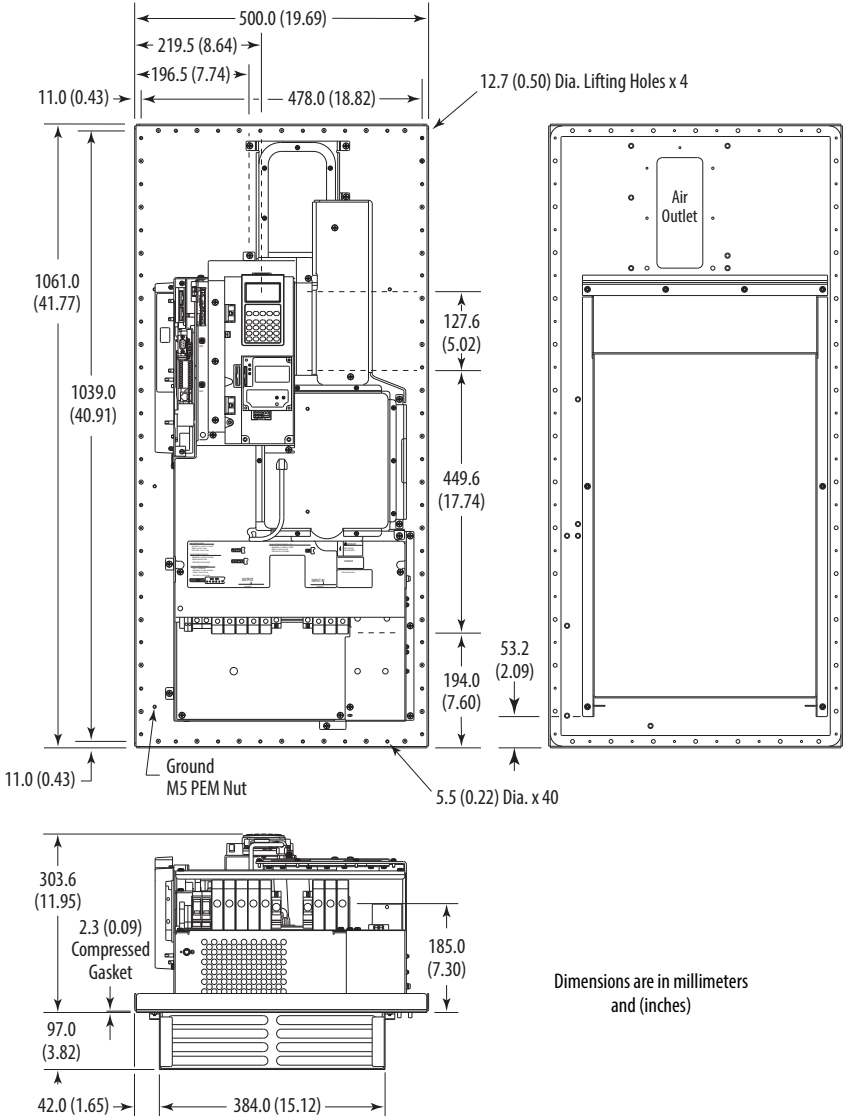

Dimensions are in millimeters and (inches)

Frame	Description	Approx. Weight ⁽¹⁾ kg (lbs.)	
		Drive	Drive & Packaging
5	Flange Mount	61.69 (136.0)	81.65 (180.0)

(1) Weights include HIM and Standard I/O.

Frame 5 – Flange Mount Cutout

4.00 (0.157) Dia. x 40, minimum 14
 GA. (1.9) steel mounting surface.
 Deburr Pilot Holes and Drive Cutout.

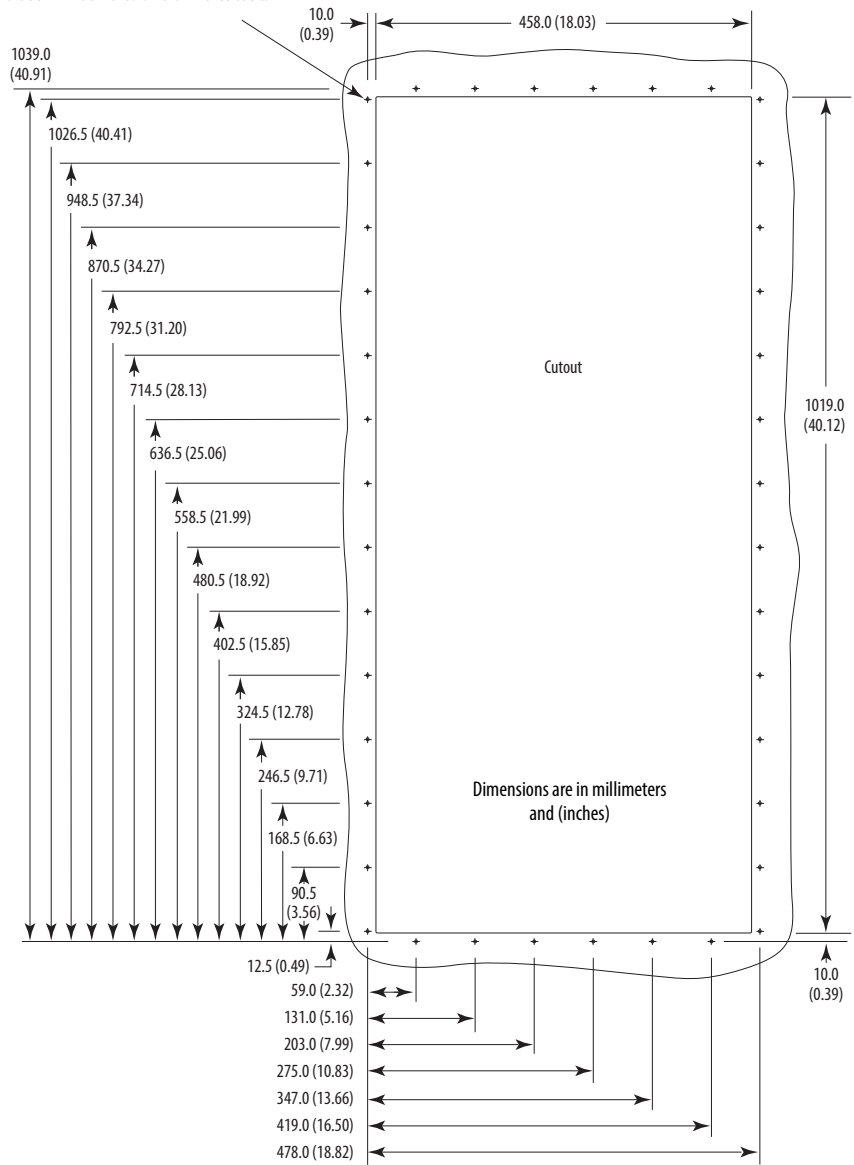

Frame 6 – IP20, NEMA/UL Type 1

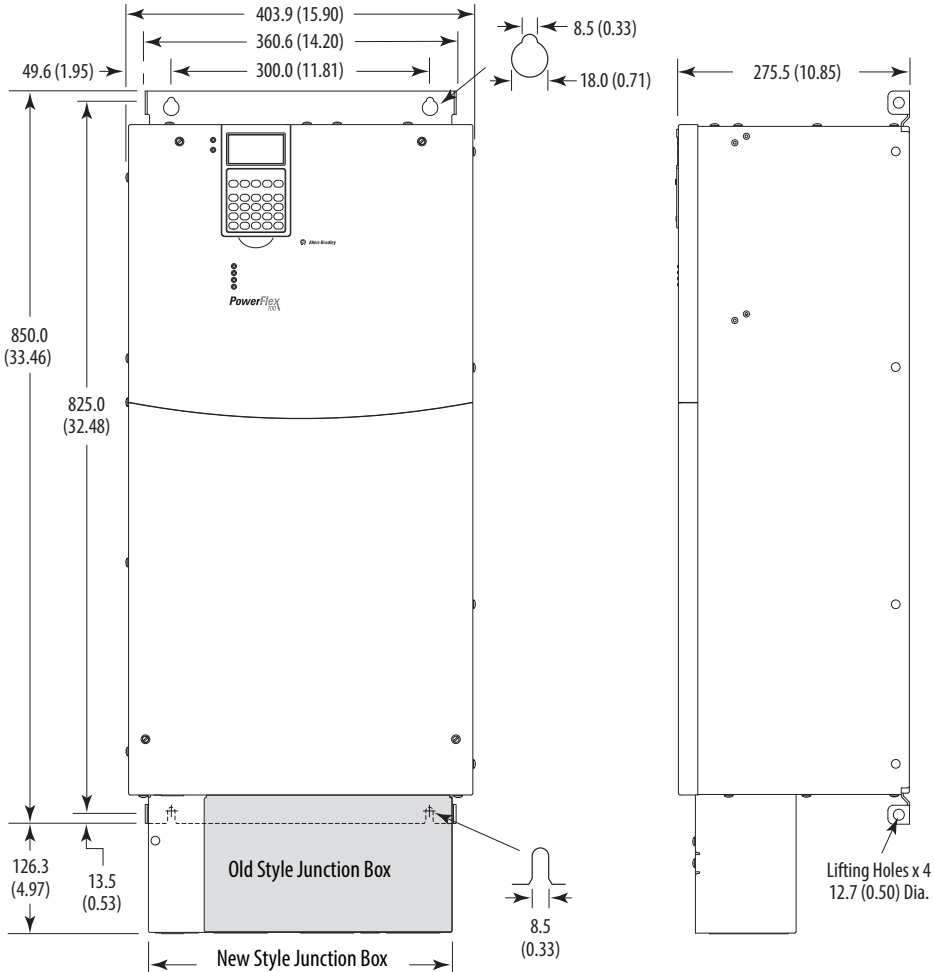

Junction Box can be removed if drive is mounted in a cabinet Dimensions are in millimeters and (inches)

Frame	Approx. Weight ⁽¹⁾ kg (lbs.)	
	Drive	Drive & Packaging
6	71.44 (157.5)	100.9 (222.0)

(1) Weights include HIM and Standard I/O. Add 13.60 kg (30.0 lbs.) for; 20BB260, 20BC260 and 20BD248.

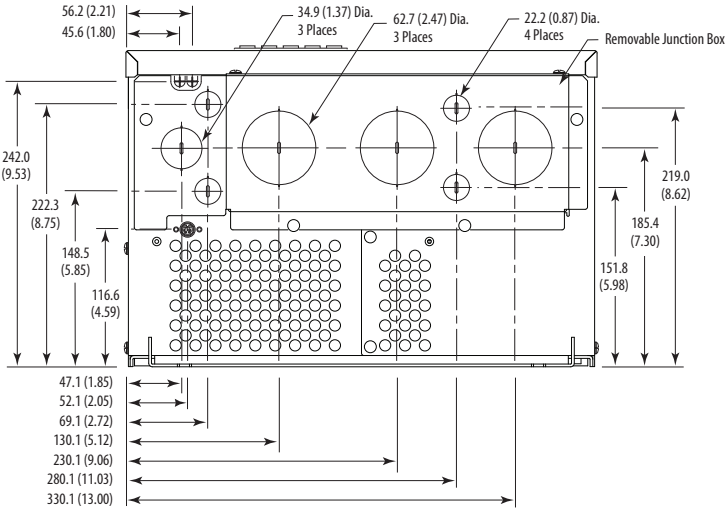

Frame 6 – IP54, NEMA Type 12 Standalone (400...690V drives only)

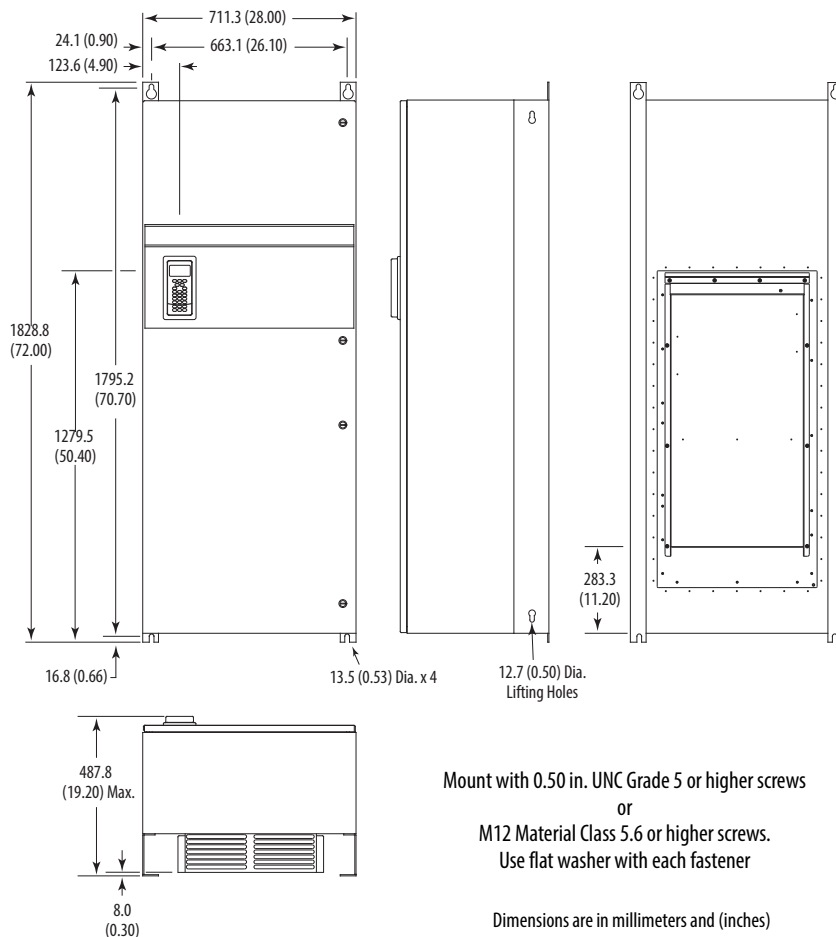

Frame	Description	Approx. Weight ⁽¹⁾ kg (lbs.)	
		Drive	Drive & Packaging
6	Standalone	176.90 (390.0)	229.07 (505.0)

(1) Weights include HIM and Standard I/O.

Frame 6 – IP54, NEMA Type 12 Flange Mount (400...690V drives only)

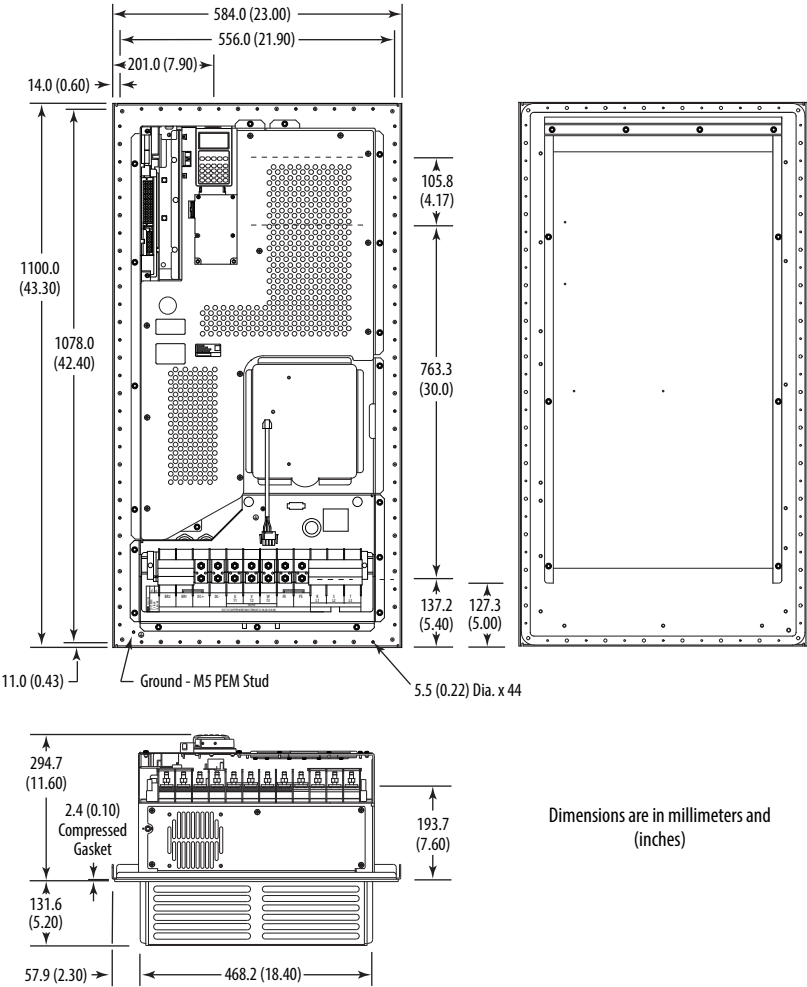

Frame	Description	Approx. Weight ⁽¹⁾ kg (lbs.)	
		Drive	Drive & Packaging
6	Flange Mount	99.79 (220.0)	119.75 (264.0)

(1) Weights include HIM and Standard I/O.

Frame 6 – Flange Mount Cutout

4.00 (0.157) Dia. x 44, minimum
 14 GA. (1.9) steel mounting surface.
 Deburr pilot holes and drive cutout.

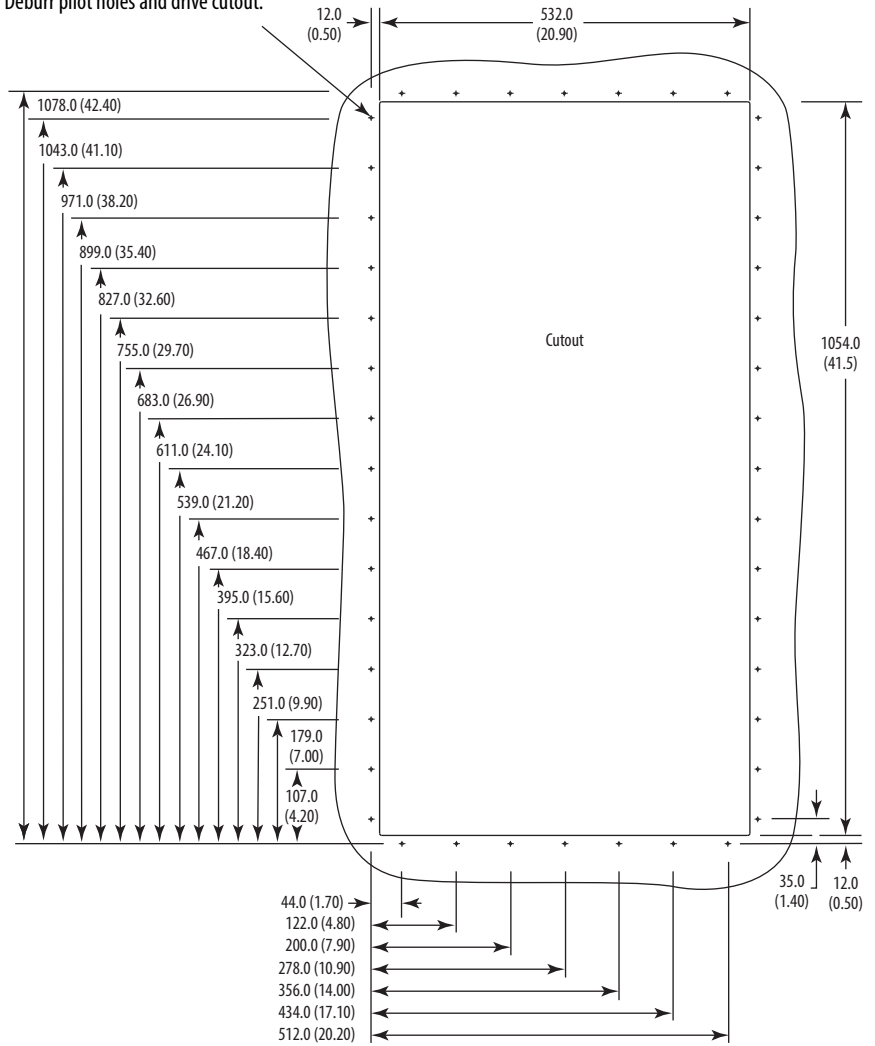

Dimensions are in millimeters and (inches)

Step 3: Wire the Drive – Power

Special Considerations

PowerFlex 700 drives are suitable for use on a circuit capable of delivering up to a maximum of 200,000 rms symmetrical amperes.



ATTENTION: To guard against personal injury and/or equipment damage caused by improper fusing or circuit breaker selection, use only the recommended line fuses/circuit breakers specified on [page 33](#).

If a system ground fault monitor (RCD) is to be used, only Type B (adjustable) devices must be used to avoid nuisance tripping.

Unbalanced, Ungrounded, Resistive or B Phase Grounded Distribution Systems

If phase to ground voltage exceeds 125% of normal line to line voltage or the supply system is ungrounded, refer to the Wiring and Grounding Guidelines for Pulse Width Modulated (PWM) AC Drives, publication [DRIVES-IN001](#).



ATTENTION: To guard against drive damage, PowerFlex 700 drives contain protective MOVs and common mode capacitors that are referenced to ground. These devices must be disconnected if the drive is not installed on a solidly grounded system. See [page 43](#) for details.

Input Power Conditioning

Certain events on the power system supplying a drive can cause component damage or shortened product life. These conditions are divided into 2 basic categories:

1. All drives

- The power system has power factor correction capacitors switched in and out of the system, either by the user or by the power company.
- The power source has intermittent voltage spikes in excess of 6000 volts. These spikes could be caused by other equipment on the line or by events such as lightning strikes.
- The power source has frequent interruptions.

2. 5 Hp or Less Drives (in addition to “1” above)

- The nearest supply transformer is larger than 100 kVA or the available short circuit (fault) current is greater than 100,000A.
- The impedance in front of the drive is less than 0.5%.

If any or all of these conditions exist, it is recommended that the user install a minimum amount of impedance between the drive and the source. This impedance could come from the supply transformer itself, the cable between the transformer and drive or an additional transformer or reactor. The impedance can be calculated by using the information supplied in Wiring and Grounding Guidelines for Pulse Width Modulated (PWM) AC Drives, publication [DRIVES-IN001](#).



ATTENTION: National Codes and standards (NEC, VDE, BSI etc.) and local codes outline provisions for safely installing electrical equipment. Installation must comply with specifications regarding wire types, conductor sizes, branch circuit protection and disconnect devices. Failure to do so can result in personal injury and/or equipment damage.

EMC Compliance

Refer to [page 7](#) for details.

Cable Trays and Conduit

If cable trays or large conduits are to be used, refer to the guidelines presented in the Wiring and Grounding Guidelines for Pulse Width Modulated (PWM) AC Drives, publication [DRIVES-IN001](#).



ATTENTION: To avoid a possible shock hazard caused by induced voltages, unused wires in the conduit must be grounded at both ends. For the same reason, if a drive sharing a conduit is being serviced or installed, all drives using this conduit must be disabled. This helps minimize the possible shock hazard from “cross coupled” motor leads.

Motor Cable Lengths

Typically, motor lead lengths less than 30 meters (100 feet) are acceptable. However, if your application dictates longer lengths, refer to the Wiring and Grounding Guidelines for Pulse Width Modulated (PWM) AC Drives, publication [DRIVES-IN001](#) or the PowerFlex 700 Technical Data, publication [20B-TD001](#).

Cable Types Acceptable for 200...600 Volt Installations

A variety of cable types are acceptable for drive installations. For many installations, unshielded cable is adequate, provided it can be separated from sensitive circuits. As an approximate guide, allow a spacing of 0.3 meters (1 foot) for every 10 meters (32.8 feet) of length. In all cases, long parallel runs must be avoided. Do not use cable with an insulation thickness less than or equal to 15 mils (0.4mm/0.015 in.). Use Copper wire only. Wire gauge requirements and recommendations are based on 75 °C. Do not reduce wire gauge when using higher temperature wire.

Unshielded Cable

THHN, THWN or similar wire is acceptable for drive installation in dry environments provided adequate free air space and/or conduit fill rates limits are provided. **Do not use THHN or similarly coated wire in wet areas.** Any wire chosen must have a minimum insulation thickness of 15 Mil and must not have large variations in insulation concentricity.

Shielded/Armored Cable

Shielded cable contains all of the general benefits of multi-conductor cable with the added benefit of a copper braided shield that can contain much of the noise generated by a typical AC Drive. Strong consideration for shielded cable must be given in installations with sensitive equipment such as weigh scales, capacitive proximity switches and other devices that can be affected by electrical noise in the distribution system. Applications with large numbers of drives in a similar location, imposed EMC regulations or a high degree of communications/networking are also good candidates for shielded cable.

Shielded cable can also help reduce shaft voltage and induced bearing currents for some applications. In addition, the increased impedance of shielded cable can help extend the distance that the motor is from the drive without the addition of motor protective devices such as terminator networks. Refer to the Reflected Wave topic in the Wiring and Grounding Guidelines for Pulse Width Modulated (PWM) AC Drives, publication [DRIVES-IN001](#).

Consideration must be given to all of the general specifications dictated by the environment of the installation, including temperature, flexibility, moisture characteristics and chemical resistance. In addition, a braided shield must be included and be specified by the cable manufacturer as having coverage of at least 75%. An additional foil shield can greatly improve noise containment.

A good example of recommended cable is Belden® 295xx (xx determines gauge). This cable has four (4) XLPE insulated conductors with a 100% coverage foil and an 85% coverage copper braided shield (with drain wire) surrounded by a PVC jacket.

Other types of shielded cable are available, but the selection of these types can limit the allowable cable length. Particularly, some of the newer cables bundle 4 conductors of THHN wire and wrap them tightly with a foil shield. This construction can greatly increase the cable charging current required and reduce the overall drive performance. Unless specified in the individual distance tables as tested with the drive, these cables are not recommended and their performance against the lead length limits supplied is not known. See [Table 3](#).

Table 3 - Recommended Shielded Wire

Location	Rating/Type	Description
Standard (Option 1)	600V, 90 °C (194 °F) XHHW2/RHW-2 Anixter B209500-B209507, Belden 29501-29507, or equivalent	<ul style="list-style-type: none"> Four tinned copper conductors with XLPE insulation. Copper braid/aluminum foil combination shield and tinned copper drain wire. PVC jacket.
Standard (Option 2)	Tray rated 600V, 90 °C (194 °F) RHH/RHW-2 Anixter OLF-7xxxx or equivalent	<ul style="list-style-type: none"> Three tinned copper conductors with XLPE insulation. 5 mil single helical copper tape (25% overlap min.) with three bare copper grounds in contact with shield. PVC jacket.
Class I & II; Division I & II	Tray rated 600V, 90 °C (194 °F) RHH/RHW-2 Anixter 7V-7xxxx-3G or equivalent	<ul style="list-style-type: none"> Three bare copper conductors with XLPE insulation and impervious corrugated continuously welded aluminum armor. Black sunlight resistant PVC jacket overall. Three copper grounds on #10 AWG and smaller.

Single-Phase Input Power

The PowerFlex 700 drive is typically used with a three-phase input supply. Single-phase operation is possible with output current derated by 50% (at maximum ambient temperature of 25 °C) of the three-phase ratings. Refer to tables 4 through 6.

AC Input Phase Selection (Frames 5...6 Only)



ATTENTION: To avoid a shock hazard, ensure that all power to the drive has been removed before performing the following.

Moving the “Line Type” jumper on the Precharge Board (see below) allows single or three-phase operation.

IMPORTANT When selecting single-phase operation, input power must be applied to the R (L1) and S (L2) terminals. This ensures that the fan is properly powered.

Typical Location - Phase Select Jumper

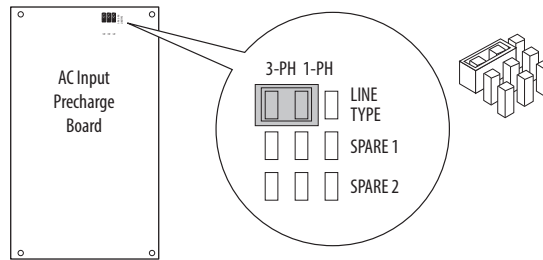

Table 4 - 208/240 Volt Single-Phase AC Input Ratings

240V Single-Phase AC Input					208V Single-Phase AC Input					Temp. °C		
Drive Catalog Number	Frame	Hp Rating	Input Amps	Three-Phase Output		Drive Catalog Number	Frame	Hp Rating	Input Amps		Three-Phase Output	
				V AC	Amps						V AC	Amps
20BB2P2	0	0.25	1.5	0-230	1.1	20BB2P2	0	0.25	1.7	0-200	1.3	25
20BB4P2	0	0.5	2.8	0-230	2.1	20BB4P2	0	0.5	3.2	0-200	2.4	25
20BB6P8	1	1	5.1	0-230	3.4	20BB6P8	1	1	5.9	0-200	3.9	25
20BB9P6	1	1.5	7.2	0-230	4.8	20BB9P6	1	1.5	8.3	0-200	5.5	25
20BB015	1	2.5	11.9	0-230	7.7	20BB015	1	2.5	13.6	0-200	8.8	25
20BB022	1	3.75	17.3	0-230	11	20BB022	1	3.75	19.9	0-200	12.7	25
20BB028	2	5	22.2	0-230	14	20BB028	2	5	25.7	0-200	16.1	25
20BB042	3	7.5	33.4	0-230	21	20BB042	3	7.5	38.5	0-200	24.2	25
20BB052	3	10	41.3	0-230	26	20BB052	3	10	44.6	0-200	28	25
20BB070	4	12.5	55.6	0-230	35	20BB070	4	12.5	62.3	0-200	39.1	25
20BB080	4	15	63.6	0-230	40	20BB080	4	15	73.3	0-200	46	25
20BB104	5	20	84.6	0-230	52	20BB104	5	20	97.9	0-200	60	25
20BB130	5	25	105.7	0-230	65	20BB130	5	25	106.1	0-200	65	25
20BB154	6	30	125.2	0-230	77	20BB154	6	30	144.4	0-200	88.5	25
20BB192	6	37.5	156.1	0-230	96	20BB192	6	37.5	180.3	0-200	110.5	25
20BB260	6	50	211.4	0-230	130	20BB260	6	50	212.1	0-200	130	25

Table 5 - 380...480 Volt Single-Phase AC Input Ratings

480V Single-Phase AC Input						380...400V Single-Phase AC Input						Temp. °C
Drive Catalog Number	Frame	Hp Rating	Input Amps	Three-Phase Output		Drive Catalog Number	Frame	kW Rating	Input Amps	Three-Phase Output		
				V AC	Amps					V AC	Amps	
20BD1P1	0	0.25	0.7	0-460	0.6	20BC1P3	0	0.2	1	0-400	0.7	25
20BD2P1	0	0.5	1.4	0-460	1.1	20BC2P1	0	0.4	1.6	0-400	1.1	25
20BD3P4	0	1	2.3	0-460	1.7	20BC3P5	0	0.75	2.7	0-400	1.8	25
20BD5P0	0	1.5	3.4	0-460	2.5	20BC5P0	0	1.1	3.9	0-400	2.5	25
20BD8P0	0	2.5	6	0-460	4	20BC8P7	0	2	6.9	0-400	4.4	25
20BD011	0	3.75	8.2	0-460	5.5	20BC011	0	2.75	9.3	0-400	5.8	25
20BD014	1	5	10.9	0-460	7	20BC015	1	3.75	12.5	0-400	7.7	25
20BD022	1	7.5	17.3	0-460	11	20BC022	1	5.5	17.8	0-400	11	25
20BD027	2	10	21.4	0-460	13.5	20BC030	2	7.5	24.6	0-400	15	25
20BD034	2	12.5	27	0-460	17	20BC037	2	9.25	30.3	0-400	18.5	25
20BD040	3	15	31.8	0-460	20	20BC043	3	11	35.2	0-400	21.5	25
20BD052	3	20	41.3	0-460	26	20BC056	3	15	45.9	0-400	28	25
20BD065	3	25	51.6	0-460	32.5	20BC072	3	18.5	59.7	0-400	36	25
20BD077	4	30	62.6	0-460	38.5	20BC085	4	22.5	70.5	0-400	42.5	25
20BD096	5	37.5	78.1	0-460	48	20BC105	5	27.5	87	0-400	52.5	25
20BD125	5	50	101.6	0-460	62.5	20BC125	5	27.5	103.6	0-400	62.5	25
–	–	–	–	–	–	20BC140	5	37.5	117.4	0-400	70	25
20BD156	6	62.5	126.8	0-460	78	20BC170	6	45	142.6	0-400	85	25
20BD180	6	75	146.4	0-460	90	20BC205	6	55	171.9	0-400	102.5	25
20BD248	6	100	201.6	0-460	124	20BC260	6	66	220.6	0-400	130	25

Table 6 - 600...690 Volt Single-Phase AC Input Rating

600V Single-Phase AC Input						690V Single-Phase AC Input						Temp. °C
Drive Catalog Number	Frame	Hp Rating	Input Amps	Three-Phase Output		Drive Catalog Number	Frame	kW Rating	Input Amps	Three-Phase Output		
				V AC	Amps					V AC	Amps	
20BE1P7	0	0.5	1.1	0-575	0.9	–	–	–	–	–	–	25
20BE2P7	0	1	1.8	0-575	1.4	–	–	–	–	–	–	25
20BE3P9	0	1.5	2.6	0-575	2	–	–	–	–	–	–	25
20BE6P1	0	2.5	4.6	0-575	3.1	–	–	–	–	–	–	25
20BE9P0	0	3.75	6.7	0-575	4.5	–	–	–	–	–	–	25
20BE011	1	5	8.5	0-575	5.5	–	–	–	–	–	–	25
20BE017	1	7.5	13.3	0-575	8.5	–	–	–	–	–	–	25
20BE022	2	10	17.5	0-575	11	–	–	–	–	–	–	25
20BE027	2	12.5	21.4	0-575	13.5	–	–	–	–	–	–	25
20BE032	3	15	25.4	0-575	16	–	–	–	–	–	–	25
20BE041	3	20	32.6	0-575	20.5	–	–	–	–	–	–	25
20BE052	3	25	41.3	0-575	26	20BF052	5	22.5	43.1	0-690	26	25
20BE062	4	30	50.4	0-575	31	20BF060	5	27.5	49.9	0-690	30	25
20BE077	5	37.5	62.6	0-575	38.5	20BF082	5	37.5	68.4	0-690	41	25
20BE099	5	50	80.5	0-575	49.5	20BF098	5	45	82	0-690	49	25
20BE125	6	62.5	101.6	0-575	62.5	20BF119	6	55	100	0-690	59.5	25
20BE144	6	75	117.1	0-575	72	20BF142	6	66	120.2	0-690	71	25

Selecting/Verifying Fan Voltage (Frames 5...6 Only)



ATTENTION: To avoid a shock hazard, ensure that all power to the drive has been removed before performing the following.

IMPORTANT Frames 5 & 6 utilize a fan transformer to power the internal fan(s). This transformer is sized specifically for the internal fan(s) and must not be used to power other circuitry.

If your line voltage is different than the voltage class specified on the drive nameplate, it can be necessary to change transformer taps as described. DC input drives require user supplied 120 or 240V AC to power the cooling fans. The power source is connected between “0 VAC” and the terminal corresponding to your source voltage.

Table 7 - Frames 5...6 Fan Connections

Drive Type	Enclosure	Rating (120VAC)	No. of Fans	Connect at ...
DC Input	IP00, NEMA/UL Type Open	100 VA (Frame 5) 138 VA (Frame 6)	1	Power Terminal Block Requires user supplied 120 or 240V AC. See page 29 for TB locations and terminal designations.
	IP20, NEMA/UL Type 1 IP54, NEMA/UL Type 12	100 VA (Frame 5) 138 VA (Frame 6)	1	
AC Input	IP00, NEMA/UL Type Open	100 VA (Frame 5) 138 VA (Frame 6)	1	N/A (Connected internally) A transformer matches the input line voltage to the internal fan voltage. If line voltage is different than the voltage class specified on the drive nameplate, the transformer taps may require changing.
	IP20, NEMA/UL Type 1 IP54, NEMA/UL Type 12	100 VA (Frame 5) 138 VA (Frame 6)	1	The transformer is behind the Power Terminal Block. Access is gained by releasing the terminal block from the rail and removing the transformer cover plate. <ol style="list-style-type: none"> 1. Locate the small metal tab at the bottom of the end terminal block. 2. Press the tab-in and pull the top of the block out. Repeat for the next block if desired. 3. Remove the transformer cover plate. 4. Select the appropriate transformer tap. 5. Replace cover and terminal block.

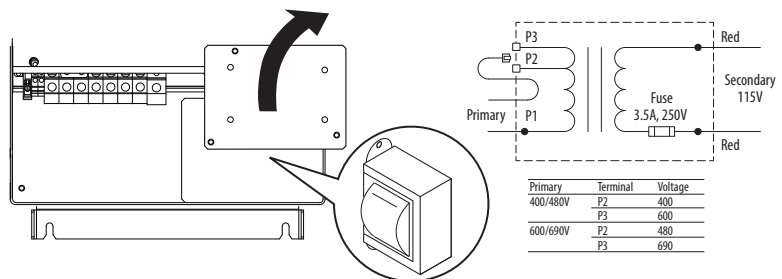

Auxiliary Control Power Supply

If desired, an auxiliary control power supply can be used with certain drives to keep the control logic up when the main AC power is removed. An auxiliary control power supply can only be used with:

- 400/480 and 600/690 Volt drives with Vector Control (15th position of the catalog number string equals “C,” or “D”).

Using an auxiliary control power supply requires the use of some type of AC line monitoring, as well as control of the Precharge Enable signal. Consult the factory for additional guidance.



ATTENTION: An Auxiliary Control Power Supply **Must Not** be used with any PowerFlex 700 Standard Control drive or 200/240 Volt Vector Control drive. Using the power supply with these drives causes equipment/component damage.

Refer to [page 29](#) for terminal block locations.

Power supply must provide

UL Installation	300V DC, $\pm 10\%$	Frames 0...3: 40 W, 165 mA, Frame 5: 80 W, 90 mA
Non UL Installation	270...600V DC, $\pm 10\%$	

Power Terminal Blocks

No.	Name	Frame	Description	Wire Size Range ⁽²⁾		Torque	
				Maximum	Minimum	Maximum	Recommended
❶	Power Terminal Block	0...1	Input power and motor connections	4.0 mm ² (12 AWG)	0.5 mm ² (22 AWG)	1.7 N•m (15 lb•in)	0.8 N•m (7 lb•in)
		2	Input power and motor connections	10.0 mm ² (8 AWG)	0.8 mm ² (18 AWG)	1.7 N•m (15 lb•in)	1.4 N•m (12 lb•in)
		3	Input power and motor connections	25.0 mm ² (3 AWG)	2.5 mm ² (14 AWG)	3.6 N•m (32 lb•in)	1.8 N•m (16 lb•in)
			BR1, 2 terminals	10.0 mm ² (8 AWG)	0.8 mm ² (18 AWG)	1.7 N•m (15 lb•in)	1.4 N•m (12 lb•in)
		4	Input power and motor connections	35.0 mm ² (2 AWG)	10.0 mm ² (8 AWG)	4.0 N•m (35 lb•in)	4.0 N•m (35 lb•in)
		5 75 Hp, 480V 100 Hp, 600V	Input power, DC+, DC-, BR1, 2, PE, motor connections	50.0 mm ² (1/0 AWG)	4.0 mm ² (12 AWG)	See Note ⁽⁴⁾	
		5 100 Hp	Input power, DC+, DC- and motor	70.0 mm ² (2/0 AWG)	10.0 mm ² (8 AWG)		
			BR1, 2, PE terminals	50.0 mm ² (1/0 AWG)	4.0 mm ² (12 AWG)		
6	Input power, DC+, DC-, BR1, 2, PE, motor connections	150.0 mm ² (300 MCM) see Note ⁽³⁾	2.5 mm ² (14 AWG)	6.0 N•m (52 lb•in)	6.0 N•m (52 lb•in)		
❷	SHLD Terminal	0...6	Terminating point for wiring shields	—	—	1.6 N•m (14 lb•in)	1.6 N•m (14 lb•in)
❸	AUX Terminal Block	0...4	Auxiliary Control Voltage PS+, PS- ⁽¹⁾	1.5 mm ² (16 AWG)	0.2 mm ² (24 AWG)	—	—
		5...6		4.0 mm ² (12 AWG)	0.5 mm ² (22 AWG)	0.6 N•m (5.3 lb•in)	0.6 N•m (5.3 lb•in)
❹	Fan Terminal Block	5...6	User Supplied Fan Voltage	4.0 mm ² (12 AWG)	0.5 mm ² (22 AWG)	0.6 N•m (5.3 lb•in)	0.6 N•m (5.3 lb•in)

(1) External control power: UL Installation-300V DC, ±10%, Non UL Installation-270...600V DC, ±10%
0...3 Frame - 40 W, 165 mA, 5 Frame - 80 W, 90 mA. Refer to the User Manual for further information.

(2) **Maximum/minimum wire sizes that the terminal block accepts - these are not recommendations.**

(3) If can be necessary to connect multiple wires in parallel to these terminals by using multiple lugs.

(4) Refer to the terminal block label inside the drive.

Typical Terminal Block Location

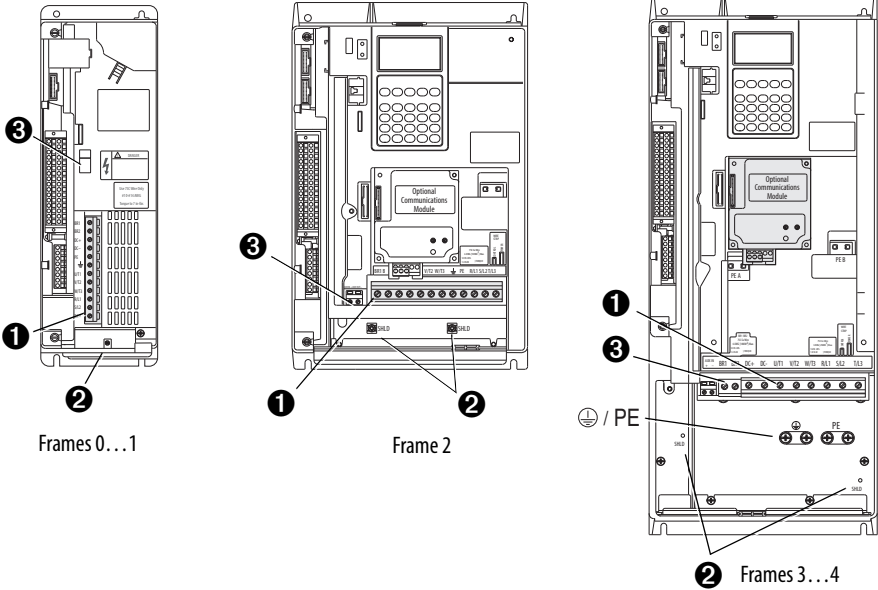

Frame 5

Frame 6

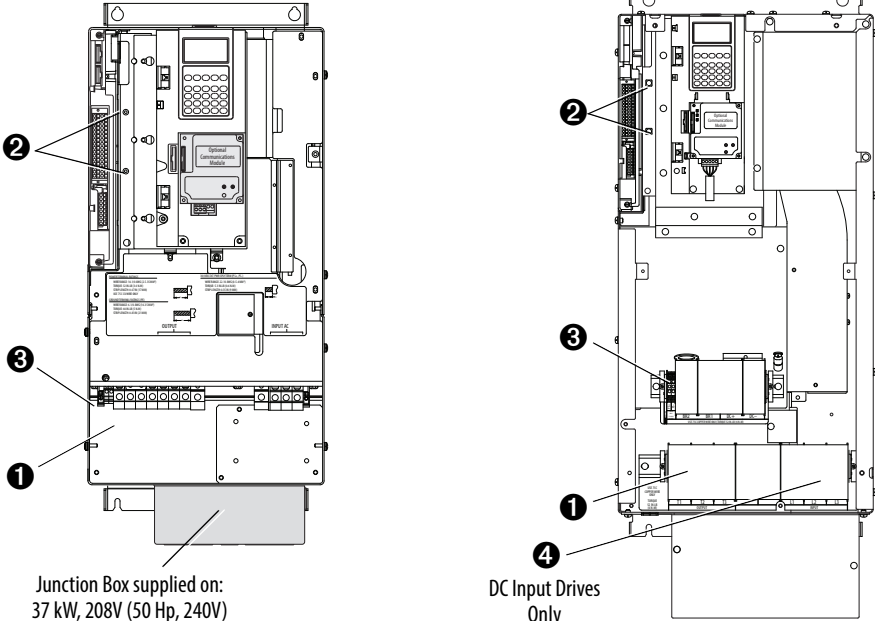

Junction Box supplied on:
 37 kW, 208V (50 Hp, 240V)
 75 kW, 400V (100 Hp, 480V)
 90kW, 690V (100 Hp, 600V)

For item number descriptions, see [page 28](#).

Terminal Block Details

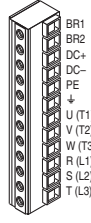
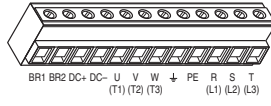
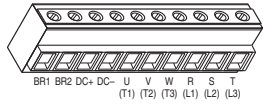
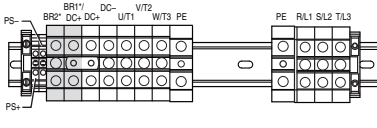
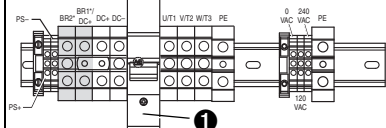
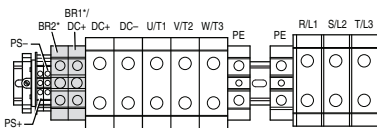
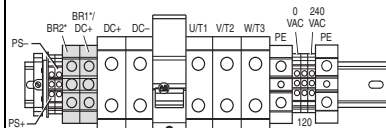
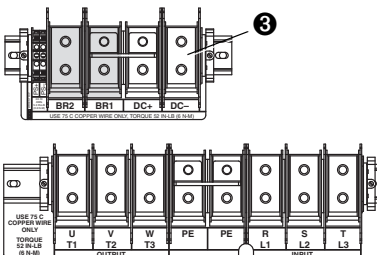
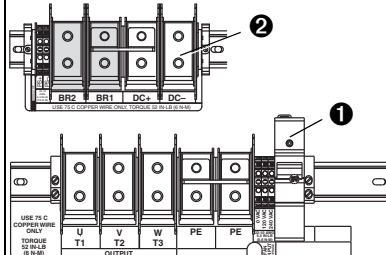
Frame	Power Terminal Blocks	
0...1		<p>Notes: Shaded BR1 & BR2 Terminals are only present on drives ordered with the Brake Option. ❶ Precharge Resistor Fuse – DCT12-2 (DC input drives w/precharge only) ❷ M8 Stud (All Terminals) Max. Lug Width = 25.4 mm (1 in.) ❸ M8 Stud (All Terminals) Max. Lug Width = 31.8 mm (1.25 in.)</p>
2		
3...4		
	AC Input (Ratings are Normal Duty)	DC Input (Ratings are Normal Duty)
5	<p>240V, 40 Hp 480V, 75 Hp 690V, 45...90 kW 400V, 55 kW 600V, 75 Hp</p> 	<p>240V, 40 Hp 480V, 75 Hp 690V, 45...90 kW 400V, 55 kW 600V, 75 Hp</p> 
	<p>240V, 50 Hp 480V, 100 Hp 400V, 75 kW 600V, 100 Hp</p> 	<p>240V, 50 Hp 480V, 100 Hp 400V, 75 kW 600V, 100 Hp</p> 
6	<p>125...200 Hp</p>  <p>USE T5-C COPPER WIRE ONLY TORQUE: 52 IN-LB (6 N-M)</p>	<p>125...200 Hp</p>  <p>USE T5-C COPPER WIRE ONLY TORQUE: 52 IN-LB (6 N-M)</p>

Terminal	Description	Notes
BR1 BR2	DC Brake (+) DC Brake (-)	DB Resistor Connection - Important: Only one DB resistor can be used with Frames 0...3. Connecting an internal & external resistor could cause damage. Twisted pair wiring must be used from these terminals to the resistor. Wiring must be routed separately from other cabling.
DC+ DC-	DC Bus (+) DC Bus (-)	DC Input/Brake Connections (chopper and resistor).
PE	PE Ground	Refer to page 29 for location on Frame 3 drives
PS+ PS-	AUX (+) AUX (-)	Auxiliary Control Voltage
	Motor Ground	Refer to page 29 for location on Frame 3 drives
U V W	U (T1) V (T2) W (T3)	To Motor/Load
R S T	R (L1) S (L2) T (L3)	AC Line Input Power Three-Phase = R, S & T Single-Phase = R & S Only (refer to User Manual for details)

Power and Ground Wiring

The drive Safety Ground - PE must be connected to system ground. Ground impedance must conform to the requirements of national and local industrial safety regulations and/or electrical codes. Periodically check the integrity of all ground connections.

For installations within a cabinet, a single safety ground point or ground bus bar connected directly to building steel must be used. All circuits including the AC input ground conductor must be grounded independently and directly to this point/bar.

Typical Grounding

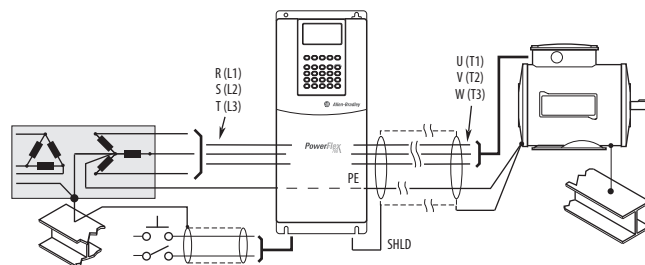

Safety Ground - PE

This is the safety ground for the drive that is required by code. This point must be connected to adjacent building steel (girder, joist), a floor ground rod or bus bar (see above). Grounding points must comply with national and local industrial safety regulations and/or electrical codes.

IMPORTANT Do Not discard or replace grounding hardware.

Shield Termination

Shield termination at “SHLD” provides a grounding point for the motor cable shield. The **motor cable** shield must be connected to this terminal on the drive (drive end) and the motor frame (motor end). A shield terminating cable gland can also be used.

When shielded cable is used for **control and signal wiring**, the shield must be grounded at the source end only, not at the drive end.

RFI Filter Grounding

Using an optional RFI filter can result in relatively high ground leakage currents. Therefore, the **filter must only be used in installations with grounded AC supply systems and be permanently installed and solidly grounded** (bonded) to the building power distribution ground. Ensure that the incoming supply neutral is solidly connected (bonded) to the same building power distribution ground. Grounding must not rely on flexible cables and must not include any form of plug or socket that permits inadvertent disconnection. Some local codes can require redundant ground connections. Periodically check the integrity of all connections. Refer to the instructions supplied with the filter.

Motor Overload Protection

Drives with Standard Control

PowerFlex 700 drives with standard control, identified by an N, A, or B in position 15 of the catalog number, only provide Class 10 motor overload protection according to NEC article 430. They do not provide speed sensitive overload protection, thermal memory retention and motor over-temperature sensing according to NEC article 430.126 (A) (2). If such protection is needed in the end-use product, it must be provided by additional means.

Drives with Vector Control

PowerFlex 700 drives with vector control, identified by a C or D in position 15 of the catalog number, provide class 10 motor overload protection according to NEC article 430 and motor over-temperature protection according to NEC article 430.126 (A) (2). UL 508C File E59272.

Drive, Fuse & Circuit Breaker Ratings

The PowerFlex 700 can be installed with input fuses or an input circuit breaker. National and local industrial safety regulations and/or electrical codes can determine additional requirements for these installations.



ATTENTION: The PowerFlex 700 does not provide branch short circuit protection. Specifications for the recommended fuse or circuit breaker to provide protection against short circuits are provided on pages [34](#) through [41](#).

The tables on the following pages provide recommended AC line input fuse and circuit breaker information. See Fusing and Circuit Breakers below for UL and IEC requirements. Sizes listed are the recommended sizes based on 40 °C (104 °F) and the U.S. NEC. Other country, state, or local codes can require different ratings. Tables with DC link fuse recommendations for DC input drives are also provided.

Fusing

The recommended fuse types are listed below. If available current ratings do not match those listed in the tables provided, choose the next higher fuse rating.

- IEC – BS88 (British Standard) Parts 1 & 2, EN60269-1, Parts 1 & 2⁽¹⁾, type gG or equivalent must be used.
- UL - UL Class CC, T, RK1 or J must be used.

Circuit Breakers

The “non-fuse” listings in the following tables include inverse time circuit breakers, instantaneous trip circuit breakers (motor circuit protectors) and 140M self-protected combination motor controllers. If one of these is chosen as the desired protection method, the following requirements apply:

- IEC – Both types of circuit breakers and 140M self-protected combination motor controllers are acceptable for IEC installations.
- UL - Only inverse time circuit breakers and the specified 140M self-protected combination motor controllers are acceptable for UL installations.

(1) Typical designations include, but may not be limited to the following; Parts 1 & 2: AC, AD, BC, BD, CD, DD, ED, EFS, EF, FF, FG, GF, GG, GH.

208 Volt AC Input Protection Devices

Drive Catalog Number	Frame	Hp Rating		PWM Freq.	Temp. (11)	Input Ratings		Output Amps			Dual Element Time Delay Fuse		Non-Time Delay Fuse		Circuit Breaker (3)	Motor Circuit Protector (4)	140M Motor Protector with Adjustable Current Range (5)(6)			Min. Enclosure Vol. (in. 3) (14)
		ND	HD	kHz	°C	Amps	kVA	Cont.	1 Min.	3 Sec.	Min. (1)	Max. (2)	Min. (1)	Max. (2)	Max. (8)	Max. (8)	Available Catalog Numbers - 140... (7)			
20BB2P2	0	0.5	0.33	4	50	1.9	0.7	2.5	2.8	3.8	3	6	3	10	15	3	M-C2E-B25	M-D8E-B25	–	7269
20BB4P2	0	1	0.75	4	50	3.7	1.3	4.8	5.6	7	6	10	6	17.5	15	7	M-C2E-B63	M-D8E-B63	–	7269
20BB6P8	1	2	1.5	4	50	6.8	2.4	7.8	10.4	13.8	10	15	10	30	30	15	M-C2E-C10	M-D8E-C10	M-F8E-C10	7269
20BB9P6	1	3	2	4	50	9.5	3.4	11	12.1	17	12	20	12	40	40	15	M-C2E-C16	M-D8E-C16	M-F8E-C16	7269
20BB015	1	5	3	4	50	15.7	5.7	17.5	19.3	26.3	20	35	20	70	70	30	M-C2E-C20	M-D8E-C20	M-F8E-C20	7269
20BB022	1	7.5	5	4	50	23	8.3	25.3	27.8	38	30	50	30	100	100	30	–	M-D8E-C25	M-F8E-C25	7269
20BB028	2	10	7.5	4	50	29.6	10.7	32.2	38	50.6	40	70	40	125	125	50	–	–	M-F8E-C32	7269
20BB042	3	15	10	4	50	44.5	16	48.3	53.1	72.5	60	100	60	175	175	70	–	–	M-F8E-C45	13630
20BB052	3	20	15	4	50	51.5	17.1	56	64	86	80	125	80	200	200	100	–	–	–	–
20BB070	4	25	20	4	50	72	25.9	78.2	93	124	90	175	90	300	300	100	–	–	–	–
20BB080	4	30	25	4	50	84.7	30.5	92	117	156	110	200	110	350	350	150	–	–	–	–
20BB104 (12)	5	40	–	4	50	113	40.7	120	132	175	150	250	150	475	350	150	–	–	–	–
		–	30	4	50	84.7	30.5	92	138	175	125	200	125	350	300	150	–	–	–	–
20BB130 (12)	5	50	–	4	50	141	44.1	130	143	175	175	275	175	500	375	250	–	–	–	–
		–	40	4	50	113	35.3	104	156	175	125	225	125	400	300	150	–	–	–	–
20BB154 (12)	6	60	–	4	50	167	60.1	177	195	266	225	350	225	500	500	250	–	–	–	–
		–	50	4	50	141	50.9	150	225	300	200	300	200	500	450	250	–	–	–	–
20BB192 (12)	6	75	–	4	50	208	75	221	243	308	300	450	300	600	600	400	–	–	–	–
		–	60	4	50	167	60.1	177	266	308	225	350	225	500	500	250	–	–	–	–
20BB260 (12)	6	100	–	2	45	255	91.9	260	286	390	300	575	300	750	750	400	–	–	–	–
		–	75	2	50	199	71.7	205	305	410	225	450	225	600	600	400	–	–	–	–

See page 38 for notes.

240 Volt AC Input Protection Devices

Drive Catalog Number	Frame	Hp Rating		PWM Freq.	Temp. (11)	Input Ratings		Output Amps			Dual Element Time Delay Fuse		Non-Time Delay Fuse		Circuit Breaker (3)	Motor Circuit Protector (4)	140M Motor Protector with Adjustable Current Range (5)(6)			Min. Enclosure Vol. (in. 3) (14)
		ND	HD	kHz	°C	Amps	kVA	Cont.	1 Min.	3 Sec.	Min. (1)	Max. (2)	Min. (1)	Max. (2)	Max. (8)	Max. (8)	Available Catalog Numbers - 140... (7)			
20BB2P2	0	0.5	0.33	4	50	1.7	0.7	2.2	2.4	3.3	3	6	3	10	15	3	M-C2E-B25	M-D8E-B25	–	7269
20BB4P2	0	1	0.75	4	50	3.3	1.4	4.2	4.8	6.4	5	8	5	15	15	7	M-C2E-B63	M-D8E-B63	–	7269
20BB6P8	1	2	1.5	4	50	5.9	2.4	6.8	9	12	10	15	10	25	25	15	M-C2E-C10	M-D8E-C10	M-F8E-C10	7269
20BB9P6	1	3	2	4	50	8.3	3.4	9.6	10.6	14.4	12	20	12	35	35	15	M-C2E-C10	M-D8E-C10	M-F8E-C10	7269
20BB015	1	5	3	4	50	13.7	5.7	15.3	16.8	23	20	30	20	60	60	30	M-C2E-C16	M-D8E-C16	M-F8E-C16	7269
20BB022	1	7.5	5	4	50	19.9	8.3	22	24.2	33	25	50	25	80	80	30	–	M-D8E-C25	M-F8E-C25	7269
20BB028	2	10	7.5	4	50	25.7	10.7	28	33	44	35	60	35	100	100	50	–	–	M-F8E-C32	7269
20BB042	3	15	10	4	50	38.5	16	42	46.2	63	50	90	50	150	150	50	–	–	M-F8E-C45	13630
20BB052	3	20	15	4	50	47.7	19.8	52	63	80	60	100	60	200	200	100	–	–	–	–
20BB070	4	25	20	4	50	64.2	26.7	70	78	105	90	150	90	275	275	100	–	–	–	–
20BB080	4	30	25	4	50	73.2	30.5	80	105	140	100	180	100	300	300	100	–	–	–	–
20BB104 (12)	5	40	–	4	50	98	40.6	104	115	175	125	225	125	400	300	150	–	–	–	–
		–	30	4	50	73	30.5	80	120	160	100	175	100	300	300	100	–	–	–	–
20BB130 (12)	5	50	–	4	50	122	50.7	130	143	175	175	275	175	500	375	250	–	–	–	–
		–	40	4	50	98	40.6	104	156	175	125	225	125	400	300	150	–	–	–	–
20BB154 (12)	6	60	–	4	50	145	60.1	154	169	231	200	300	200	600	450	250	–	–	–	–
		–	50	4	50	122	50.7	130	195	260	175	275	175	500	375	250	–	–	–	–
20BB192 (12)	6	75	–	4	50	180	74.9	192	211	288	225	400	225	600	575	250	–	–	–	–
		–	60	4	50	145	60.1	154	231	308	200	300	200	600	450	250	–	–	–	–
20BB260 (12)	6	100	–	2	45	233	96.7	260	286	390	300	575	300	750	750	300	–	–	–	–
		–	75	2	50	169	70.1	205	305	410	225	450	225	600	600	250	–	–	–	–

See page 38 for notes.

400 Volt AC Input Protection Devices

Drive Catalog Number	Frame	kW Rating		PWM Freq.	Temp.	Input Ratings		Output Amps			Dual Element Time Delay Fuse		Non-Time Delay Fuse		Circuit Breaker (3)	Motor Circuit Protector (4)	140M Motor Protector with Adjustable Current Range (5)(6)			
		ND	HD	kHz	°C	Amps	kVA	Cont.	1 Min.	3 Sec.	Min. (1)	Max. (2)	Min. (1)	Max. (2)	Max. (8)	Max. (8)	Available Catalog Numbers - 140... (7)			Min. Enclosure Vol. (in. 3) (14)
20BC1P3	0	0.37	0.25	4	50 ⁽¹¹⁾	1.1	0.77	1.3	1.4	1.9	3	3	3	6	15	3	M-C2E-B16	–	–	7269
20BC2P1	0	0.75	0.55	4	50 ⁽¹¹⁾	1.8	1.3	2.1	2.4	3.2	3	6	3	8	15	3	M-C2E-B25	M-D8E-B25	–	7269
20BC3P5	0	1.5	0.75	4	50 ⁽¹¹⁾	3.2	2.2	3.5	4.5	6	6	7	6	12	15	7	M-C2E-B40	M-D8E-B40	–	7269
20BC5P0	0	2.2	1.5	4	50 ⁽¹¹⁾	4.6	3.2	5	5.5	7.5	6	10	6	20	20	7	M-C2E-B63	M-D8E-B63	–	7269
20BC8P7	0	4	2.2	4	50 ⁽¹¹⁾	7.9	5.5	8.7	9.9	13.2	15	17.5	15	30	30	15	M-C2E-C10	M-D8E-C10	M-F8E-C10	7269
20BC011	0	5.5	4	4	50 ⁽¹¹⁾	10.8	7.5	11.5	13	17.4	15	25	15	45	45	15	M-C2E-C16	M-D8E-C16	M-F8E-C16	7269
20BC015	1	7.5	5.5	4	50 ⁽¹¹⁾	14.4	10	15.4	17.2	23.1	20	30	20	60	60	20	M-C2E-C20	M-D8E-C20	M-F8E-C20	7269
20BC022	1	11	7.5	4	50 ⁽¹¹⁾	20.6	14.3	22	24.2	33	30	45	30	80	80	30	–	M-D8E-C25	M-F8E-C25	7269
20BC030	2	15	11	4	50 ⁽¹¹⁾	28.4	19.7	30	33	45	35	60	35	120	120	50	–	–	M-F8E-C32	7269
20BC037	2	18.5	15	4	50 ⁽¹¹⁾	35	24.3	37	45	60	45	80	45	125	125	50	–	–	M-F8E-C45	7269
20BC043	3	22	18.5	4	50 ⁽¹¹⁾	40.7	28.2	43	56	74	60	90	60	150	150	60	–	–	–	–
20BC056	3	30	22	4	50 ⁽¹¹⁾	53	36.7	56	64	86	70	125	70	200	200	100	–	–	–	–
20BC072	3	37	30	4	50 ⁽¹⁰⁾⁽¹¹⁾	68.9	47.8	72	84	112	90	150	90	250	250	100	–	–	–	–
20BC085 ⁽¹²⁾	4	45	–	4	45 ⁽¹¹⁾	81.4	56.4	85	94	128	110	200	110	300	300	150	–	–	–	–
		–	37	4	45 ⁽¹¹⁾	68.9	47.8	72	108	144	90	175	90	275	300	100	–	–	–	–
20BC105 ⁽¹²⁾	5	55	–	4	50 ⁽⁹⁾	100.5	69.6	105	116	158	125	225	125	400	300	150	–	–	–	–
		–	45	4	50 ⁽⁹⁾	81.4	56.4	85	128	170	110	175	110	300	300	150	–	–	–	–
20BC125 ⁽¹²⁾	5	55	–	4	50 ⁽⁹⁾	121.1	83.9	125	138	163	150	275	150	500	375	250	–	–	–	–
		–	45	4	50 ⁽⁹⁾	91.9	63.7	96	144	168	125	200	125	375	375	150	–	–	–	–
20BC140 ⁽¹²⁾	5	75	–	4	40 ⁽⁹⁾	136	93.9	140	154	190	200	300	200	400	400	250	–	–	–	–
		–	55	4	40 ⁽⁹⁾	101	69.6	105	157	190	150	225	150	300	300	150	–	–	–	–
20BC170 ⁽¹²⁾	6	90	–	4	50 ⁽⁹⁾	164	126	170	187	255	250	375	250	600	500	250	–	–	–	–
		–	75	4	50 ⁽⁹⁾	136	103	140	210	280	200	300	200	550	400	250	–	–	–	–
20BC205 ⁽¹²⁾	6	110	–	4	40 ⁽⁹⁾	199	148	205	220	289	250	450	250	600	600	400	–	–	–	–
		–	90	4	40 ⁽⁹⁾	164	126	170	255	313	250	375	250	600	500	250	–	–	–	–
20BC260 ⁽¹²⁾	6	132	–	2	45 ⁽⁹⁾	255	177	260	286	390	350	550	350	750	750	400	–	–	–	–
		–	110	2	50 ⁽⁹⁾	199	138	205	308	410	250	450	250	600	600	400	–	–	–	–

See [page 38](#) for notes.

480 Volt AC Input Protection Devices

Drive Catalog Number	Frame	Hp Rating		PWM Freq.	Temp.	Input Ratings		Output Amps			Dual Element Time Delay Fuse		Non-Time Delay Fuse		Circuit Breaker (3)	Motor Circuit Protector (4)	140M Motor Protector with Adjustable Current Range (5)(6)			
		ND	HD	kHz	°C	Amps	kVA	Cont.	1 Min.	3 Sec.	Min. (1)	Max. (2)	Min. (1)	Max. (2)	Max. (8)	Max. (8)	Available Catalog Numbers - 140... (7)			Min. Enclosure Vol. (in. 3) (14)
20BD1P1	0	0.5	0.33	4	50 ⁽¹¹⁾	0.9	0.7	1.1	1.2	1.6	3	3	3	6	15	3	M-C2E-B16	-	-	7269
20BD2P1	0	1	0.75	4	50 ⁽¹¹⁾	1.6	1.4	2.1	2.4	3.2	3	6	3	8	15	3	M-C2E-B25	-	-	7269
20BD3P4	0	2	1.5	4	50 ⁽¹¹⁾	2.6	2.2	3.4	4.5	6	4	8	4	12	15	7	M-C2E-B40	M-D8E-B40	-	7269
20BD5P0	0	3	2	4	50 ⁽¹¹⁾	3.9	3.2	5	5.5	7.5	6	10	6	20	20	7	M-C2E-B63	M-D8E-B63	-	7269
20BD8P0	0	5	3	4	50 ⁽¹¹⁾	6.9	5.7	8	8.8	12	10	15	10	30	30	15	M-C2E-C10	M-D8E-C10	M-F8E-C10	7269
20BD011	0	7.5	5	4	50 ⁽¹¹⁾	9.5	7.9	11	12.1	16.5	15	20	15	40	40	15	M-C2E-C16	M-D8E-C16	M-F8E-C16	7269
20BD014	1	10	7.5	4	50 ⁽¹¹⁾	12.5	10.4	14	16.5	22	17.5	30	17.5	50	50	20	M-C2E-C16	M-D8E-C16	M-F8E-C16	7269
20BD022	1	15	10	4	50 ⁽¹¹⁾	19.9	16.6	22	24.2	33	25	50	25	80	80	30	-	M-D8E-C25	M-F8E-C25	7269
20BD027	2	20	15	4	50 ⁽¹¹⁾	24.8	20.6	27	33	44	35	60	35	100	100	50	-	-	M-F8E-C32	7269
20BD034	2	25	20	4	50 ⁽¹¹⁾	31.2	25.9	34	40.5	54	40	70	40	125	125	50	-	-	M-F8E-C45	7269
20BD040	3	30	25	4	50 ⁽¹¹⁾	36.7	30.5	40	51	68	50	90	50	150	150	50	-	-	M-F8E-C45	13630
20BD052	3	40	30	4	50 ⁽¹¹⁾	47.7	39.7	52	60	80	60	110	60	200	200	70	-	-	-	-
20BD065	3	50	40	4	50 ⁽¹¹⁾	59.6	49.6	65	78	104	80	125	80	250	250	100	-	-	-	-
20BD077 (12)	4	60	-	4	50 ⁽¹¹⁾	72.3	60.1	77	85	116	100	170	100	300	300	100	-	-	-	-
	-	50	4	50 ⁽¹¹⁾	59.6	49.6	65	98	130	80	125	80	250	250	100	-	-	-	-	-
20BD096 (12)	5	75	-	4	50 ⁽⁹⁾	90.1	74.9	96	106	144	125	200	125	350	350	125	-	-	-	-
	-	60	4	50 ⁽⁹⁾	72.3	60.1	77	116	154	100	170	100	300	300	100	-	-	-	-	-
20BD125 (12)	5	100	-	4	50 ⁽⁹⁾	117	97.6	125	138	163	150	250	150	500	375	150	-	-	-	-
	-	75	4	50 ⁽⁹⁾	90.1	74.9	96	144	168	125	200	125	350	350	125	-	-	-	-	-
20BD156 (12)	6	125	-	4	50 ⁽⁹⁾	147	122	156	172	234	200	350	200	600	450	250	-	-	-	-
	-	100	4	50 ⁽⁹⁾	131	109	125	188	250	175	250	175	500	375	250	-	-	-	-	-
20BD180 (12)	6	150	-	4	50 ⁽⁹⁾	169	141	180	198	270	225	400	225	600	500	250	-	-	-	-
	-	125	4	50 ⁽⁹⁾	147	122	156	234	312	200	350	200	600	450	250	-	-	-	-	-
20BD248 (12)	6	200	-	2	45 ⁽⁹⁾	233	194	248	273	372	300	550	300	700	700	400	-	-	-	-
	-	150	2	50 ⁽⁹⁾	169	141	180	270	360	225	400	225	600	500	250	-	-	-	-	-

See [page 38](#) for notes.

600 Volt AC Input Protection Devices⁽¹³⁾

Drive Catalog Number	Frame	Hp Rating		PWM Freq.	Temp. ⁽¹¹⁾	Input Ratings		Output Amps			Dual Element Time Delay Fuse		Non-Time Delay Fuse		Circuit Breaker ⁽³⁾	Motor Circuit Protector ⁽⁴⁾	140M Motor Protector with Adjustable Current Range ⁽⁵⁾⁽⁶⁾			
		ND	HD	kHz	°C	Amps	kVA	Cont.	1 Min.	3 Sec.	Min. ⁽¹⁾	Max. ⁽²⁾	Min. ⁽¹⁾	Max. ⁽²⁾	Max. ⁽⁸⁾	Max. ⁽⁸⁾	Available Catalog Numbers - 140... ⁽⁷⁾			Min. Enclosure Vol. (in. ³) ⁽¹⁴⁾
20BE1P7	0	1	0.5	4	50	1.3	1.4	1.7	2	2.6	2	4	2	6	15	3	M-C2E-B16	–	–	7269
20BE2P7	0	2	1	4	50	2.1	2.1	2.7	3.6	4.8	3	6	3	10	15	3	M-C2E-B25	–	–	7269
20BE3P9	0	3	2	4	50	3	3.1	3.9	4.3	5.9	6	9	6	15	15	7	M-C2E-B40	M-D8E-B40	–	7269
20BE6P1	0	5	3	4	50	5.3	5.5	6.1	6.7	9.2	9	12	9	20	20	15	–	M-D8E-B63	–	7269
20BE9P0	0	7.5	5	4	50	7.8	8.1	9	9.9	13.5	10	20	10	35	30	15	–	M-D8E-C10	M-F8E-C10	7269
20BE011	1	10	7.5	4	50	9.9	10.2	11	13.5	18	15	25	15	40	40	15	–	M-D8E-C10	M-F8E-C10	7269
20BE017	1	15	10	4	50	15.4	16	17	18.7	25.5	20	40	20	60	50	20	–	M-D8E-C16	M-F8E-C16	7269
20BE022	2	20	15	4	50	20.2	21	22	25.5	34	30	50	30	80	80	30	–	–	M-F8E-C25	7269
20BE027	2	25	20	4	50	24.8	25.7	27	33	44	35	60	35	100	100	50	–	–	M-F8E-C25	7269
20BE032	3	30	25	4	50	29.4	30.5	32	40.5	54	40	70	40	125	125	50	–	–	M-F8E-C32	13630
20BE041	3	40	30	4	50	37.6	39.1	41	48	64	50	90	50	150	150	100	–	–	–	–
20BE052	3	50	40	4	50	47.7	49.6	52	61.5	82	60	110	60	200	200	100	–	–	–	–
20BE062	4	60	50	2	50	58.2	60.5	62	78	104	80	125	80	225	225	100	–	–	–	–
20BE077 ⁽¹²⁾	5	75	–	2	50 ⁽⁹⁾	72.3	75.1	77	85	116	90	150	90	300	300	100	–	–	–	–
		–	60	2	50 ⁽⁹⁾	58.2	60.5	63	94	126	90	125	90	250	250	100	–	–	–	–
20BE099 ⁽¹²⁾	5	100	–	2	40 ⁽⁹⁾	92.9	96.6	99	109	126	125	200	125	375	375	150	–	–	–	–
		–	75	2	40 ⁽⁹⁾	72.3	75.1	77	116	138	100	175	100	300	300	100	–	–	–	–
20BE125 ⁽¹²⁾	6	125	–	2	50 ⁽⁹⁾	117	122	125	138	188	150	250	150	375	375	250	–	–	–	–
		–	100	2	50 ⁽⁹⁾	93	96.6	99	149	198	125	200	125	375	375	150	–	–	–	–
20BE144 ⁽¹²⁾	6	150	–	2	50 ⁽⁹⁾	135	141	144	158	216	175	300	175	400	400	250	–	–	–	–
		–	125	2	50 ⁽⁹⁾	117	122	125	188	250	150	275	150	375	375	250	–	–	–	–

See page 38 for notes.

Table 8 - 690 Volt AC Input Protection Devices⁽¹³⁾

Drive Catalog Number	Frame	kW Rating		PWM Freq.	Temp. ⁽¹¹⁾	Input Ratings		Output Amps			Dual Element Time Delay Fuse		Non-Time Delay Fuse		Circuit Breaker ⁽³⁾	Motor Circuit Protector ⁽⁴⁾
		ND	HD	kHz	°C	Amps	kVA	Cont.	1 Min.	3 Sec.	Min. ⁽¹⁾	Max. ⁽²⁾	Min. ⁽¹⁾	Max. ⁽²⁾	Max. ⁽⁸⁾	Max. ⁽⁸⁾
20BF052 ⁽¹²⁾	5	45	–	4	50 ⁽⁹⁾	46.9	56.1	52	57	78	60	110	60	175	175	–
		–	37.5	4	50 ⁽⁹⁾	40.1	48	46	69	92	50	90	50	150	150	–
20BF060 ⁽¹²⁾	5	55	–	4	50 ⁽⁹⁾	57.7	68.9	60	66	90	80	125	80	225	225	–
		–	45	4	50 ⁽⁹⁾	46.9	56.1	52	78	104	60	110	60	175	175	–
20BF082 ⁽¹²⁾	5	75	–	2	50 ⁽⁹⁾	79	94.4	82	90	123	100	200	100	375	375	–
		–	55	2	50 ⁽⁹⁾	57.7	68.9	60	90	120	80	125	80	225	225	–
20BF098 ⁽¹²⁾	5	90	–	2	40 ⁽⁹⁾	94.7	113	98	108	127	125	200	125	375	375	–
		–	75	2	40 ⁽⁹⁾	79	94.4	82	123	140	100	200	100	375	375	–
20BF119 ⁽¹²⁾	6	110	–	2	50 ⁽⁹⁾	115	137	119	131	179	150	250	150	400	–	–
		–	90	2	50 ⁽⁹⁾	94.7	113	98	147	196	125	200	125	375	–	–
20BF142 ⁽¹²⁾	6	132	–	2	50 ⁽⁹⁾	138	165	142	156	213	175	300	175	450	–	–
		–	110	2	50 ⁽⁹⁾	115	137	119	179	238	150	250	150	400	–	–

See page 38 for notes.

Notes

- (1) Minimum protection device size is the lowest rated device that supplies maximum protection without nuisance tripping.
- (2) Maximum protection device size is the highest rated device that supplies drive protection. For US NEC, minimum size is 125% of motor FLA. Ratings shown are maximum.
- (3) Circuit Breaker - inverse time breaker. For US NEC, minimum size is 125% of motor FLA. Ratings shown are maximum.
- (4) Motor Circuit Protector - instantaneous trip circuit breaker. For US NEC minimum size is 125% of motor FLA. Ratings shown are maximum.
- (5) Bulletin 140M with adjustable current range must have the current trip set to the minimum range that the device will not trip.
- (6) Manual Self-Protected (Type E) Combination Motor Controller, UL listed for 208 Wye or Delta, 240 Wye or Delta, 480Y/277 or 600Y/347. Not UL listed for use on 480V or 600V Delta/Delta, corner ground, or high-resistance ground systems.
- (7) The AIC ratings of the Bulletin 140M Motor Protector Circuit Breakers can vary. See [Bulletin 140M Motor Protection Circuit Breakers Application Ratings](#).
- (8) Maximum allowable rating by US NEC. Exact size must be chosen for each installation.
- (9) UL Type 12/IP54 (flange mount) heat sink ambient temperature rating is 40° C/ambient of unprotected drive portion (inside enclosure) is 55° C. The ambient temperature for the UL Type 12/IP54 stand-alone drives is 40° C.
- (10) Must remove top label and vent plate, drive enclosure rating is IP00, NEMA/UL Type Open.
- (11) Drive frames 0...4 temperature rating is for NEMA/UL Type Open. The adhesive top label must be removed to operate drive at this temperature. Frames 5 & 6 do not have a top label.
- (12) Drives have dual current ratings; one for normal duty applications, and one for heavy duty applications. The drive can be operated at either rating.
- (13) Note: 600V class drives below 77 Amps (Frames 0...4) are declared to meet the Low Voltage Directive. It is the responsibility of the user to determine compliance to the EMC directive.
- (14) When using a Manual Self-Protected (Type E) Combination Motor Controller, the drive must be installed in a ventilated or non-ventilated enclosure with the minimum volume specified in this column. Application specific thermal considerations can require a larger enclosure.

325 Volt DC Input Protection Devices

Drive Catalog Number	Frame	Hp Rating		PWM Freq. kHz	Temp. (1) °C	DC Input Ratings Amps	Output Amps			Fuse	Non-Time Delay Fuse (2) (11)
		ND	HD				Cont.	1 Min.	3 Sec.		
20BB2P2	0	0.5	0.33	4	50	2	2.2	2.4	3.3	5	JKS-5
20BB4P2	0	1	0.75	4	50	3.8	4.2	4.8	6.4	10	JKS-10
20BB6P8	1	2	1.5	4	50	6.9	6.8	9	12	15	HSJ15
20BB9P6	1	3	2	4	50	9.7	9.6	10.6	14.4	20	HSJ20
20BB015	1	5	3	4	50	16	15.3	16.8	23	30	HSJ30
20BB022	1	7.5	5	4	50	23.3	22	24.2	33	45	HSJ45
20BB028	2	10	7.5	4	50	30	28	33	44	60	HSJ60
20BB042	3	15	10	4	50	45	42	46.2	63	90	HSJ90
20BB052	3	20	15	4	50	55	52	63	80	100	HSJ100
20BB070	4	25	20	4	50	75.3	70	78	105	150	HSJ150
20BB080	4	30	25	4	50	86.8	80	105	140	175	HSJ175
20BN104 (3)	5	40	—	4	50	114.1	104	115	175	200	HSJ200
		—	30	4	50	85.8	80	120	160	200	HSJ200
20BN130 (3)	5	50	—	4	50	142.6	130	143	175	200	HSJ200
		—	40	4	50	114.1	104	156	175	200	HSJ200
20BN154 (3)	6	60	—	4	50	169	154	169	231	300	HSJ300
		—	50	4	50	142.6	130	195	260	300	HSJ300
20BN192 (3)	6	75	—	4	50	210.6	192	211	288	350	HSJ350
		—	60	4	50	169	154	231	308	350	HSJ350
20BN260 (3)	6	100	—	2	45	285.3	260	286	390	400	HSJ400
		—	75	2	50	210.6	205	305	410	400	HSJ400

See [page 41](#) for notes.

540 Volt DC Input Protection Devices

Drive Catalog Number	Frame	kW Rating		PWM Freq.	Temp. (1)	DC Input Ratings	Output Amps			Fuse	Non-Time Delay Fuse (2)(11)
		ND	HD	kHz	°C	Amps	Cont.	1 Min.	3 Sec.		
20BC1P3	0	0.37	0.25	4	50	1.3	1.3	1.4	1.9	3	JKS-3
20BC2P1	0	0.75	0.55	4	50	2.1	2.1	2.4	3.2	6	JKS-6
20BC3P5	0	1.5	0.75	4	50	3.7	3.5	4.5	6	8	JKS-8
20BC5P0	0	2.2	1.5	4	50	5.3	5	5.5	7.5	10	JKS-10
20BC8P7	0	4	3	4	50	9.3	8.7	9.9	13.2	15	HSJ15
20BC011	0	5.5	4	4	50	12.6	11.5	13	17.4	20	HSJ20
20BC015	1	7.5	5.5	4	50	16.8	15.4	17.2	23.1	25	HSJ25
20BC022	1	11	7.5	4	50	24	22	24.2	33	40	HSJ40
20BC030	2	15	11	4	50	33.2	30	33	45	50	HSJ50
20BC037	2	18.5	15	4	50	40.9	37	45	60	70	HSJ70
20BC043	3	22	18.5	4	50	47.5	43	56	74	90	HSJ90
20BC056	3	30	22	4	50	61.9	56	64	86	100	HSJ100
20BC072	3	37	30	4	50 ⁽⁷⁾	80.5	72	84	112	125	HSJ125
20BC085 ⁽³⁾⁽⁵⁾	4	45	–	4	45	95.1	85	94	128	150	HSJ150
		–	37	4	45	80.5	72	108	144	175	HSJ175
20BH105 ⁽³⁾⁽⁵⁾	5	55	–	4	50 ⁽⁴⁾	120.2	105	116	158	175	HSJ175
		–	45	4	50 ⁽⁴⁾	95.1	85	128	170	200	HSJ200
20BH140 ⁽³⁾⁽⁵⁾	5	75	–	4	40 ⁽⁴⁾	159	140	154	190	225	HSJ225
		–	55	4	40 ⁽⁴⁾	120.2	105	158	190	225	HSJ225
20BH170 ⁽³⁾⁽⁵⁾	6	90	–	4	50 ⁽⁴⁾	192.3	170	187	255	300	HSJ300
		–	75	4	50 ⁽⁴⁾	159	140	210	280	300	HSJ300
20BH205 ⁽³⁾⁽⁵⁾	6	110	–	4	40 ⁽⁴⁾	226	205	220	289	350	HSJ350
		–	90	4	40 ⁽⁴⁾	192.3	170	255	313	350	HSJ350
20BH260 ⁽³⁾⁽⁵⁾	6	132	–	2	45 ⁽⁴⁾	298	260	286	390	500	HSJ500
		–	110	2	50 ⁽⁴⁾	226	205	305	410	500	HSJ500

See [page 41](#) for notes.

650 Volt DC Input Protection Devices

Drive Catalog Number	Frame	Hp Rating		PWM Freq. kHz	Temp. (1) °C	DC Input Ratings Amps	Output Amps			Fuse	Non-Time Delay Fuse (2)(11)
		ND	HD				Cont.	1 Min.	3 Sec.		
20BD1P1	0	0.5	0.33	4	50	1.0	1.1	1.2	1.6	3	JKS-3
20BD2P1	0	1	0.75	4	50	1.9	2.1	2.4	3.2	6	JKS-6
20BD3P4	0	2	1.5	4	50	3.0	3.4	4.5	6.0	6	JKS-6
20BD5P0	0	3	2	4	50	4.5	5.0	5.5	7.5	10	JKS-10
20BD8P0	0	5	3	4	50	8.1	8.0	8.8	12	15	HSJ15
20BD011	0	7.5	5	4	50	11.1	11	12.1	16.5	20	HSJ20
20BD014	1	10	7.5	4	50	14.7	14	16.5	22	30	HSJ30
20BD022	1	15	10	4	50	23.3	22	24.2	33	40	HSJ40
20BD027	2	20	15	4	50	28.9	27	33	44	50	HSJ50
20BD034	2	25	20	4	50	36.4	34	40.5	54	60	HSJ60
20BD040	3	30	25	4	50	42.9	40	51	68	80	HSJ80
20BD052	3	40	30	4	50	55.7	52	60	80	90	HSJ90
20BD065	3	50	40	4	50	69.7	65	78	104	100	HSJ100
20BD077 ⁽³⁾	4	60	–	4	50	84.5	77	85	116	150	HSJ150
		–	50	4	50	69.7	65	98	130	150	HSJ150
20BR096 ⁽³⁾⁽⁶⁾	5	75	–	4	50 ⁽⁴⁾	105.3	96	106	144	175	HSJ175
		–	60	4	50 ⁽⁴⁾	84.5	77	116	154	175	HSJ175
20BR125 ⁽³⁾⁽⁶⁾	5	100	–	4	50 ⁽⁴⁾	137.1	125	138	163	200	HSJ200
		–	75	4	50 ⁽⁴⁾	105.3	96	144	168	200	HSJ200
20BR156 ⁽³⁾⁽⁶⁾	6	125	–	4	50 ⁽⁴⁾	171.2	156	172	234	300	HSJ300
		–	100	4	50 ⁽⁴⁾	137.1	125	188	250	300	HSJ300
20BR180 ⁽³⁾⁽⁶⁾	6	150	–	4	50 ⁽⁴⁾	204	180	198	270	400	HSJ400
		–	125	4	50 ⁽⁴⁾	171.2	156	234	312	400	HSJ400
20BR248 ⁽³⁾⁽⁶⁾	6	200	–	2	45 ⁽⁴⁾	272	248	273	372	400	HSJ400
		–	150	2	50 ⁽⁴⁾	204	180	270	360	400	HSJ400

See page 41 for notes.

810 Volt DC Input Protection Devices

Drive Catalog Number	Frame	Hp Rating		PWM Freq. kHz	Temp. (1) °C	DC Input Ratings Amps	Output Amps			Fuse	Non-Time Delay Fuse (2)(11)
		ND	HD				Cont.	1 Min.	3 Sec.		
20BE1P7	0	1	0.75	4	50	1.5	1.7	2	2.6	3	JKS-3
20BE2P7	0	2	1.5	4	50	2.4	2.7	3.6	4.8	6	JKS-6
20BE3P9	0	3	2	4	50	3.5	3.9	4.3	5.9	6	JKS-6
20BE6P1	0	5	3	4	50	6.2	6.1	6.7	9.2	10	JKS-10
20BE9P0	0	7.5	5	4	50	9.1	9	9.9	13.5	15	HSJ15
20BE011	0	10	7.5	4	50	11.5	11	13.5	18	20	HSJ20
20BE017	1	15	10	4	50	18	17	18.7	25.5	30	HSJ30
20BE022	2	20	15	4	50	23.6	22	25.5	34	40	HSJ40
20BE027	2	25	20	4	50	29	27	33	44	50	HSJ50
20BE032	3	30	25	4	50	34.3	32	40.5	54	60	HSJ60
20BE041	3	40	30	4	50	43.9	41	48	64	70	HSJ70
20BE052	3	50	40	4	50	55.7	52	61.5	82	90	HSJ90
20BE062	4	60	50	2	50	68	62	78	104	125	HSJ125
20BT099 ⁽³⁾	5	100	–	2	40	108.6	99	109	126	150	HSJ150
		–	75	2	40	84.5	77	116	138	150	HSJ150
20BT144 ⁽³⁾	6	150	–	2	50	158	144	158	216	250	HSJ250
		–	125	2	50	137.1	125	188	250	250	HSJ250

See page 41 for notes.

932 Volt DC Input Protection Devices

Drive Catalog Number	Frame	kW Rating		PWM Freq.	Temp. (1)	DC Input Ratings	Output Amps			Fuse	Non-Time Delay Fuse (2)(11)
		ND	HD	kHz	°C	Amps	Cont.	1 Min.	3 Sec.		
20BW052 ⁽³⁾	5	45	–	2	50 ⁽⁴⁾	58.2	52	57	78	100	170M3691
		–	37.5	2	50 ⁽⁴⁾	46.9	46	69	92	100	170M3691
20BW098 ⁽³⁾	5	90	–	2	50 ⁽⁴⁾	110.7	98	108	127	160	170M3693
		–	75	2	50 ⁽⁴⁾	92.3	82	123	140	160	170M3693
20BW142 ⁽³⁾	6	132	–	2	50 ⁽⁴⁾	162.2	142	156	213	250	170M3695
		–	110	2	40 ⁽⁴⁾	134.9	119	179	238	315	170M3696

Notes

- (1) Frames 0...4 temperature rating is for NEMA/UL Type Open. The adhesive top label must be removed to operate drive at this temperature. Frames 5 & 6 do not have a top label.
- (2) The power source to common bus inverters must be derived from AC voltages 600V or less, as defined in NFPA70; Art 430-18 (NEC). Battery supplies or MG sets are not included. The following devices were validated to break current of the derived power DC Bus. Disconnects: Allen-Bradley Bulletin 1494, 30-400A; 194, 30-400A; or ABB OESA, 600 & 800A; OESL, all sizes. Fuses: Bussmann Type JKS, all sizes; Type 170M, Case Sizes 1, 2 and 3, or Ferraz Shawmut Type HSI, all sizes. For any other devices, please contact the factory.
- (3) Drives have dual current ratings; one for normal duty applications, and one for heavy duty applications. The drive can be operated at either rating.
- (4) UL Type 12/IP54 (flange mount) heatsink ambient temperature rating is 40 °C/ambient of unprotected drive portion (inside enclosure) is 55 °C. The ambient temperature for the UL Type 12/IP54 stand-alone drives is 40 °C.
- (5) Also applies to "P" voltage class.
- (6) Also applies to "J" voltage class.
- (7) Must remove top label and vent plate, drive enclosure rating is IP00, NEMA/UL Type Open.
- (8) Two 630A Bussmann 170M6608 can also be used.
- (9) Two 700A Bussmann 170M6611 can also be used.
- (10) Bussmann or equivalent.
- (11) See Fuse Certification and Test Data in PowerFlex AC Drives in Common Bus Configurations Application Guidelines, publication [DRIVES-AT002](#), for fuse self-certification and test data for Bussmann 170M and JKS fuses recommended for the DC bus fusing.

Output Devices

Common mode cores are internal to the drive. For information on output contactors see [page 42](#). Other devices such as cable terminators and output reactors are discussed in Wiring and Grounding Guidelines for Pulse Width Modulated (PWM) AC Drives, publication DRIVES-IN001.

Using Input/Output Contactors

Input Contactor Precautions



ATTENTION: A contactor or other device that routinely disconnects and reapplies the AC line to the drive to start and stop the motor can cause drive hardware damage. The drive is designed to use control input signals that start and stop the motor. If an input device is used, operation must not exceed one cycle per minute or drive damage occurs.



ATTENTION: The drive start/stop/enable control circuitry includes solid state components. If hazards due to accidental contact with moving machinery or unintentional flow of liquid, gas or solids exist, an additional hardwired stop circuit can be required to remove the AC line to the drive. An auxiliary braking method can be required.

Output Contactor Precaution



ATTENTION: To guard against drive damage when using output contactors, the following information must be read and understood. One or more output contactors can be installed between the drive and motor(s) for the purpose of disconnecting or isolating certain motors/loads. If a contactor is opened while the drive is operating, power is removed from the respective motor, but the drive continues to produce voltage at the output terminals. In addition, reconnecting a motor to an active drive (by closing the contactor) could produce excessive current that can cause the drive to fault. If any of these conditions are determined to be undesirable or unsafe, an auxiliary contact on the output contactor must be wired to a drive digital input that is programmed as "Enable." This causes the drive to execute a coast-to-stop (cease output) whenever an output contactor is opened.

Bypass Contactor Precaution



ATTENTION: An incorrectly applied or installed bypass system can result in component damage or reduction in product life. The most common causes are:

- Wiring AC line to drive output or control terminals.
- Improper bypass or output circuits not approved by Allen-Bradley.
- Output circuits that do not connect directly to the motor.

Contact Allen-Bradley for assistance with application or wiring.

Disconnecting MOVs and Common Mode Capacitors

The Powerflex 700 drive contains protective MOVs and Common Mode Capacitors referenced to ground (see below). To guard against unstable operation and/or damage, the drive must be properly configured as shown in [Table 9](#) on [page 44](#).

MOV and AC EMI Capacitor Phase to Ground

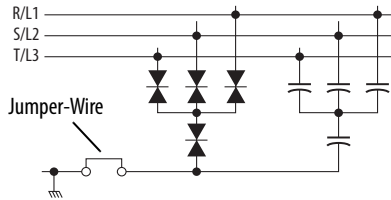

Common Mode Capacitor to Ground

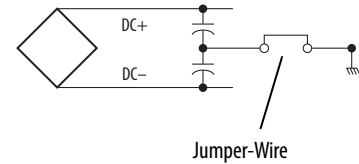

IMPORTANT All PowerFlex 700 drives are shipped with the DC bus common mode capacitors referenced to ground.

Before proceeding, ensure that all power to the drive has been removed.



ATTENTION: Only qualified personnel familiar with adjustable frequency AC drives and associated machinery must perform maintenance/repair of the system. Failure to comply can result in personal injury and/or equipment damage.



ATTENTION: To avoid an electric shock hazard, verify that the voltage on the bus capacitors has discharged before performing any work on the drive. Measure the DC bus voltage at the following points (refer to pages [29](#) through [30](#) for locations):

- +DC and -DC terminals of the Power Terminal Block
- +DC terminal of the Power Block and the chassis
- -DC terminal of the Power Terminal Block and the chassis

The voltage must be zero for all three measurements.



ATTENTION: The following information is merely a guide for proper installation. Rockwell Automation cannot assume responsibility for the compliance or the noncompliance to any code, national, local or otherwise for the proper installation of this drive or associated equipment. A hazard of personal injury and/or equipment damage exists if codes are ignored during installation.

Table 9 - Recommended Power Jumper Configurations

Power Source Type ⁽¹⁾	MOV/Input Filter Caps ⁽²⁾	DC Bus Common Mode Caps	Benefits Of Correct Configuration on Power Source Type
Solid Ground <ul style="list-style-type: none"> AC fed, solidly grounded DC fed from passive rectifier that has an AC source and solid ground 	Connected	Connected	<ul style="list-style-type: none"> Reduced electrical noise, Most stable operation, EMC compliance, Reduced voltage stress on components and motor bearings.
Non-Solid Ground <ul style="list-style-type: none"> AC fed ungrounded Impedance grounded High resistive ground B phase ground Regenerative unit such as common DC bus supply & brake DC fed from an active converter 	Disconnected	Disconnected	<ul style="list-style-type: none"> Helps avoid severe equipment damage when ground fault occurs.

(1) It is highly recommended to accurately determine the power source type and then configure appropriately.

(2) When MOVs are disconnected, the power system must have its own transient protection to ensure known and controlled voltages.

To connect or disconnect these devices, refer to pages [45](#) through [51](#).

IMPORTANT Common mode capacitors are used to conform with the EMC directives. Removing these devices can withdraw the associated directive.

In addition, on an ungrounded distribution system where the line-to-ground voltages on any phase could exceed 125% of the nominal line-to-line voltage, an isolation transformer must be installed. See Wiring and Grounding Guidelines for PWM AC Drives, publication DRIVES-IN001 for more information on impedance grounded and ungrounded systems.

Jumper Installation, Removal and Storage

PowerFlex 700 drives utilize plug-in style jumpers and jumper wires. Most drives have a jumper storage area inside the front cover. Store extra jumpers or jumpers that have been removed in this location for use at a later time.

Insulating Jumper Wires

Some drives are designed to utilize nylon screws and spacers to insulate jumper wires from ground and secure them to the chassis. The components must be installed as shown.



Drive Identification

Refer to the drive nameplate and locate the “Voltage Code,” “Current Rating,” “Frame,” and “UL Type” (Frames 5...6). Use this information to locate the proper procedure in the following tables.

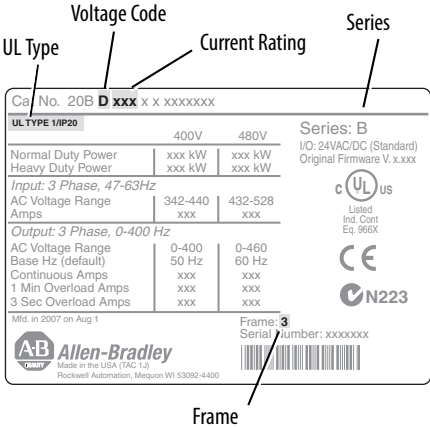

Jumper Settings and Locations

Frame	Voltage Code	Current Rating	Factory Default Jumper Settings		Power Source Type
			MOV/ Input Filter Caps	DC Bus Common Mode Caps	
0...1	All Drives				
	B...E	All	PE_B Installed	PE_A Installed	<p>Solid Ground</p> <ul style="list-style-type: none"> Remove the I/O Cassette (see page 53). Verify that jumpers are installed at the “PE_A” and “PE_B” locations on the Power Board. <p>Non-Solid Ground</p> <ul style="list-style-type: none"> Remove the I/O Cassette (see page 53). Remove jumpers at the “PE_A” and “PE_B” locations on the Power Board.
2	All Drives				
	B...E	All	PE_MOV Installed	PE_CAP Installed	<p>Solid Ground</p> <ul style="list-style-type: none"> Verify that jumpers are installed at the “PE_CAP” and “PE_MOV” locations. <p>Non-Solid Ground</p> <ul style="list-style-type: none"> Remove jumpers at the “PE_CAP” and “PE_MOV” locations.

Frame	Voltage Code	Current Rating	Factory Default Jumper Settings		Power Source Type
			MOV/Input Filter Caps ⁽¹⁾⁽²⁾	DC Bus Common Mode Caps	
3...4	All Drives (continued)				
	B...E	All	PE_MOV Installed	PE-CAP Installed	<p>Solid Ground</p> <ul style="list-style-type: none"> Verify that jumpers are installed at the "PE_CAP" and "PE_MOV" locations. <p>Non-Solid Ground</p> <ul style="list-style-type: none"> Remove jumpers at the "PE_CAP" and "PE_MOV" locations.
5	IP20, NEMA/UL Type 1 and Open Drives				
	B C D H J N P R	All except C140	Two green/yellow wires <u>connected</u> to the Power Terminal Block rail	Green/yellow wire is <u>connected</u> to ground	<p>Solid Ground</p> <ol style="list-style-type: none"> CM Cap jumper wire must be connected to ground with a metal screw. Verify, and if necessary: <ul style="list-style-type: none"> Newer Drives - Remove the nylon screw/spacer and insert a metal M5 x 8 screw. Torque to 3.2 N·m (28 lb·in). Older Drives - Remove the I/O Cassette (see page 53). The green/yellow CM Cap jumper wire is on the back of chassis and must be connected to ground with a metal screw. Remove the insulation from the wire terminal and connect to chassis with a metal M5 x 12 screw. Torque to 3.2 N·m (28 lb·in). MOV/Input Filter Cap jumper wires must be connected to ground with a metal screw. Verify, and if necessary, remove the nylon screw/spacer and insert a metal M5 x 12 screw. <p>Non-Solid Ground</p> <ol style="list-style-type: none"> CM Cap jumper wire must be insulated from ground. Verify, and if necessary: <ul style="list-style-type: none"> Newer Drives - Remove the metal screw and insert a M5 x 15 nylon screw/spacer. Older Drives - Remove the I/O Cassette (see page 53). Insulate/secure jumper wire to guard against unintentional contact with chassis or components. MOV/Input Filter Cap jumper wires must be insulated from ground with a nylon screw/spacer. Verify, and if necessary, remove the metal screw and insert a M5 x 20 nylon screw/spacer.

Frame 5 continued on next page

(1) AC input drives only. MOV's and input filter caps do not exist on DC input drives.

(2) When removing MOV's, the input filter capacitor must also be removed.

Frame	Voltage Code	Current Rating	Factory Default Jumper Settings		Power Source Type
			MOV / Input Filter Caps ⁽¹⁾⁽²⁾	DC Bus Common Mode Caps	
5	IP20, NEMA/UL Type 1 and Open Drives (continued)				
	C F W	140 052 060	Two green/yellow wires <u>connected</u> to the Power Terminal Block rail	Green/yellow wire to CM Cap Board is <u>connected</u> to ground	<p>Solid Ground</p> <ol style="list-style-type: none"> 1. CM Cap jumper wire must be connected to ground with a metal screw. Verify, and if necessary, remove the nylon screw/spacer and insert a metal M5 x 8 screw. Torque to 3.2 N-m (28 lb-in). 2. MOV/Input Filter Cap jumper wires must be connected to ground with a metal screw. Verify, and if necessary, remove the nylon screw/spacer and insert a metal M5 x 12 screw. <p>Non-Solid Ground</p> <ol style="list-style-type: none"> 1. CM Cap jumper wire must be insulated from ground with a nylon screw/spacer. Verify, and if necessary, remove the metal screw and insert a M5 x 15 nylon screw/spacer. 2. MOV/Input Filter Cap jumper wires must be insulated from ground with a nylon screw/spacer. Verify, and if necessary, remove the metal screw and insert a M5 x 20 nylon screw/spacer.
	<p>MOV / Input Filter Cap</p>				
E F T W	077 082 099 098	Two green/yellow wires <u>connected</u> to chassis ground	Green/yellow wire to CM Cap Board is <u>connected</u> to ground	<p>Solid Ground</p> <ol style="list-style-type: none"> 1. CM Cap jumper wire must be connected to ground with a metal screw. Verify, and if necessary, remove the nylon screw/spacer and insert a metal M5 x 8 screw. Torque to 3.2 N-m (28 lb-in). 2. MOV jumper wire must be connected to ground with metal screws. Verify, and if necessary, remove the nylon screw/spacers and insert a metal M5 x 12 screws. 3. Input Filter Cap jumper wire must be connected to ground with a metal screw. Verify, and if necessary, remove the nylon screw/spacer and insert metal M5 x 8 screw. <p>Non-Solid Ground</p> <ol style="list-style-type: none"> 1. CM Cap jumper wire must be insulated from ground with a nylon screw/spacer. Verify, and if necessary, remove the metal screw and insert a M5 x 15 nylon screw/spacer. 2. MOV jumper wire must be insulated from ground with a nylon screw/spacer. Verify, and if necessary, remove the metal screws and insert a M5 x 20 nylon screw/spacer. 3. Input Filter Cap jumper wire must be insulated from ground with a nylon screw/spacer. Verify, and if necessary, remove the metal screws and insert a M5 x 15 nylon screw/spacer. 	
<p>MOV</p>					

Frame 5 continued on next page

(1) AC input drives only. MOV's and input filter caps do not exist on DC input drives.
 (2) When removing MOV's, the input filter capacitor must also be removed.

Frame	Voltage Code	Current Rating	Factory Default Jumper Settings		Power Source Type
			MOV/ Input Filter Caps ⁽¹⁾⁽²⁾	DC Bus Common Mode Caps	
5	IP54, NEMA Type 12 Drives				
	C D P R	All	Two green/yellow wires <u>connected</u> to chassis ground	Green/yellow wire is <u>connected</u> to ground	<p>Solid Ground</p> <ol style="list-style-type: none"> CM Cap jumper wire must be connected to ground with a metal screw. Verify, and if necessary: <ul style="list-style-type: none"> Newer Drives - Remove the nylon screw/ spacer and insert a metal M5 x 8 screw. Torque to 3.2 N•m (28 lb•in). Older Drives - Remove the I/O Cassette (see page 53). The green/yellow CM Cap jumper wire is on the back of chassis and must be connected to ground with a metal screw. Remove the insulation from the wire terminal and connect to chassis with a metal M5 x 10 screw. Torque screw to 3.2 N•m (28 lb•in). MOV/Input Filter Cap jumper wires must be connected to ground with a metal screw. Verify, and if necessary, remove the nylon screw/spacer and insert a metal M5 x 12 screw. <p>Non-Solid Ground</p> <ol style="list-style-type: none"> CM Cap jumper wire must be insulated from ground. Verify, and if necessary: <ul style="list-style-type: none"> Newer Drives - Remove the metal screw and insert a M5 x 15 nylon screw/spacer. Older Drives - Remove the I/O Cassette (see page 53). Insulate/secure jumper wire to guard against unintentional contact with chassis or components. MOV/Input Filter Cap jumper wires must be insulated from ground with a nylon screw/spacer. Verify, and if necessary, remove the metal screw and insert a M5 x 20 nylon screw/spacer.

Frame 5 continued on next page

- (1) AC input drives only. MOV's and input filter caps do not exist on DC input drives.
- (2) When removing MOV's, the input filter capacitor must also be removed.

Frame	Voltage Code	Current Rating	Factory Default Jumper Settings		Power Source Type
			MOV / Input Filter Caps ⁽¹⁾⁽²⁾	DC Bus Common Mode Caps	
5	IP54, NEMA Type 12 Drives (continued)				
	E F T W	All	Two green/yellow wires <u>connected</u> to chassis ground	Green/yellow wire to CM Cap Board is <u>connected</u> to ground	<p>Solid Ground</p> <ol style="list-style-type: none"> CM Cap jumper wire must be connected to ground with a metal screw. Verify, and if necessary, remove the nylon screw/spacer and insert a metal M5 x 12 screw. Torque to 3.2 N·m (28 lb·in). MOV/Input Filter Cap jumper wires must be connected to ground with a metal screw. Verify, and if necessary, remove the nylon screw/spacer and insert a metal M5 x 12 screw. <p>Non-Solid Ground</p> <ol style="list-style-type: none"> CM Cap jumper wire must be insulated from ground with a nylon screw/spacer. Verify, and if necessary, remove the metal screw and insert a M5 x 20 nylon screw/spacer. MOV/Input Filter Cap jumper wires must be insulated from ground with a nylon screw/spacer. Verify, and if necessary, remove the metal screw and insert a M5 x 20 nylon screw/spacer.

(1) AC input drives only. MOV's and input filter caps do not exist on DC input drives.
 (2) When removing MOV's, the input filter capacitor must also be removed.

Frame	Voltage Code	Current Rating	Factory Default Jumper Settings		Power Source Type
			MOV / Input Filter Caps ⁽¹⁾⁽²⁾	DC Bus Common Mode Caps	
6	IP20, NEMA/UL Type 1 and Open Drives				
B C D H J N P R	All	Two green/yellow wires <u>connected</u> to Power Terminal Block "PE"	Green/yellow wire to CM Cap Board is <u>connected</u> to Power Terminal Block "PE"	<p>Solid Ground</p> <ol style="list-style-type: none"> 1. The green/yellow CM Cap jumper wire must be connected to "PE." 2. The MOV/Input Filter Cap jumper wires must be connected to "PE." <p>Non-Solid Ground</p> <ol style="list-style-type: none"> 1. The green/yellow CM Cap jumper wire must be insulated from ground. Verify, and if necessary, remove the jumper wire from "PE" and insulate/secure it to guard against unintentional contact with chassis or components. Important: Do Not Remove/Disconnect the larger green/yellow wire. 2. MOV/Input Filter Cap jumper wires must be insulated from ground. Verify, and if necessary, remove the jumper wires from "PE" and individually insulate/secure each jumper wire to guard against unintentional contact with chassis or components. 	

Frame 6 continued on next page

(1) AC input drives only. MOV's and input filter caps do not exist on DC input drives.

(2) When removing MOV's, the input filter capacitor must also be removed.

Frame	Voltage Code	Current Rating	Factory Default Jumper Settings		Power Source Type
			MOV/ Input Filter Caps ⁽¹⁾⁽²⁾	DC Bus Common Mode Caps	
6	IP20, NEMA/UL Type 1 and Open Drives (continued)				
	E F T W	All	Two green/yellow wires <u>connected</u> to Power Terminal Block "PE" and chassis	Green/yellow wire to CM Cap Board is <u>connected</u> to Power Terminal Block "PE"	<p>Solid Ground</p> <ol style="list-style-type: none"> The green/yellow CM Cap and MOV jumper wires must be connected to "PE." The Input Filter Cap jumper wire (top right) must be connected to chassis ground with a metal screw. Verify, and if necessary, remove the nylon screw/spacer and insert a metal M5 x 10 screw. Torque to 3.2 N·m (28 lb-in). <p>Non-Solid Ground</p> <ol style="list-style-type: none"> The green/yellow CM Cap and MOV jumper wires must be insulated from ground. Verify, and if necessary, remove them from "PE" and individually insulate/secure each jumper wire to guard against unintentional contact with chassis or components. Important: Do Not Remove/Disconnect the larger green/yellow wire. The Input Filter Cap jumper wire (top right) must be insulated from ground with a nylon screw/spacer. Verify, and if necessary, remove the metal screw and insert a M5 x 15 nylon screw/spacer.
6	IP54, NEMA Type 12 Drives				
	C D E F P R T W	All	Two green/yellow wires <u>connected</u> to Power Terminal Block "PE"	Green/yellow wire to CM Cap Board is <u>connected</u> to Power Terminal Block "PE"	<p>Solid Ground</p> <ol style="list-style-type: none"> The green/yellow CM Cap jumper wire must be connected to "PE." The MOV/Input Filter Cap jumper wires must be connected to "PE." <p>Non-Solid Ground</p> <ol style="list-style-type: none"> The green/yellow CM Cap jumper wire must be insulated from ground. Verify, and if necessary, remove the jumper wire from "PE" and insulate/secure it to guard against unintentional contact with chassis or components. Important: Do Not Remove/Disconnect the larger green/yellow wire. MOV/Input Filter Cap jumper wires must be insulated from ground. Verify, and if necessary, remove the jumper wires from "PE" and individually insulate/secure them to guard against unintentional contact with chassis or components.

(1) AC input drives only. MOV's and input filter caps do not exist on DC input drives.
 (2) When removing MOV's, the input filter capacitor must also be removed.

Step 4: I/O Wiring

Important points to remember about I/O wiring:

- Use Copper wire only. Wire gauge requirements and recommendations are based on 75 degrees C. Do not reduce wire gauge when using higher temperature wire.
- Wire with an insulation rating of 600V or greater is recommended.
- Separate control and signal wires from power wires by at least 0.3 meters (1 foot).

IMPORTANT I/O terminals labeled “(-)” or “Common” are not referenced to earth ground and are designed to greatly reduce common mode interference. Grounding these terminals can cause signal noise.



ATTENTION: Configuring an analog input for 0...20 mA operation and driving it from a voltage source could cause component damage. Verify proper configuration prior to applying input signals.



ATTENTION: Hazard of personal injury or equipment damage exists when using bipolar input sources. Noise and drift in sensitive input circuits can cause unpredictable changes in motor speed and direction. Use speed command parameters to help reduce input source sensitivity.

Wire Recommendations

Type		Wire Type(s)	Description	Min. Insulation Rating
Signal (1)(2)(3)	Standard Analog I/O	Belden 8760/9460 (or equivalent)	0.750 mm ² (18 AWG), twisted pair, 100% shield with drain.	300V, 75...90 °C (167...194 °F)
		Belden 8770 (or equivalent)	0.750 mm ² (18 AWG), 3 conductor, shielded for remote pot only.	
	Encoder/Pulse I/O < 30 m (100 ft.)	Combined: Belden 9730 ⁽⁴⁾	0.196 mm ² (24 AWG), individually shielded	
	Encoder/Pulse I/O 30 to 152 m (100 to 500 ft.)	Signal: Belden 9730/9728 ⁽⁴⁾	0.196 mm ² (24 AWG), individually shielded	
		Power: Belden 8790 ⁽⁵⁾	0.750 mm ² (18 AWG)	
		Combined: Belden 9892 ⁽⁶⁾	0.330 mm ² (22 AWG) or 0.500 mm ² (20 AWG)	
	Encoder/Pulse I/O 152 to 259 m (500 to 850 ft.)	Signal: Belden 9730/9728 ⁽⁴⁾	0.196 mm ² (24 AWG), individually shielded	
Power: Belden 8790 ⁽⁵⁾		0.750 mm ² (18 AWG)		
Combined: Belden 9773/9774 ⁽⁷⁾		0.750 mm ² (18 AWG), individually shielded		
Digital I/O (1)(2)(3)	Shielded	Multi-conductor shielded cable such as Belden 8770 (or equivalent)	0.750 mm ² (18 AWG), 3 conductor, shielded.	300V, 60 °C (140 °F)
	Unshielded	Per US NEC or applicable national or local code	–	

(1) Separate control and signal wires from power wires by at least 0.3 meters (1 foot).

(2) If the wires are short and contained within a cabinet that has no sensitive circuits, the use of shielded wire can not be necessary, but is always recommended.

(3) I/O terminals labeled “(-)” or “Common” are not referenced to earth ground and are designed to greatly reduce common mode interference. Grounding these terminals can cause signal noise.

(4) 9730 is 3 individually shielded pairs (2 channel + power). If 3 channel is required, use 9728.

(5) 8790 is 1 shielded pair.

(6) 9892 is 3 individually shielded pairs (3 channel) + 1 shielded pair for power.

(7) 9773 is 3 individually shielded pairs (2 channel + power). If 3 channel is required, use 9774.

I/O Terminals

The figure below shows the I/O Control Cassette and terminal block locations. The cassette provides a mounting point for the various PowerFlex 700 I/O options. To remove the cassette, follow the steps below. Cassette removal is similar for all frames (Frame 0 drive shown).

Step	Description
(A)	Disconnect the two cable connectors shown below.
(B)	Loosen the two screw latches shown below.
(C)	Slide the cassette out.
(D)	Remove screws securing cassette cover to gain access to the boards.

PowerFlex 700 Typical Cassette & I/O Terminal Blocks

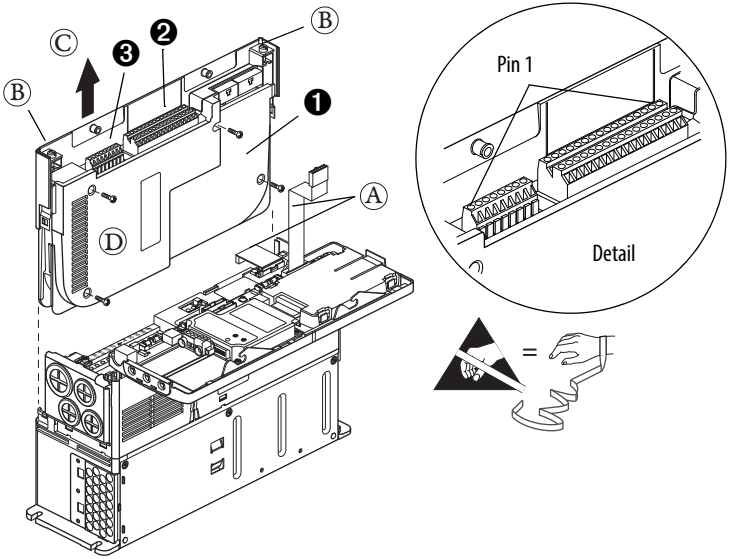

I/O Terminal Block Specifications

No.	Name	Description	Wire Size Range ⁽¹⁾		Torque	
			Maximum	Minimum	Maximum	Recommended
1	I/O Cassette	Removable I/O Cassette				
2	I/O Terminal Block	Signal & control connections	2.5 mm ² (14 AWG)	0.30 mm ² (22 AWG)	0.6 N•m (5.3 lb•in)	0.6 N•m (5.3 lb•in)
3	Encoder Terminal Block	Encoder power & signal connections	0.75 mm ² (18 AWG)	0.196 mm ² (24 AWG)	0.6 N•m (5.3 lb•in)	0.6 N•m (5.3 lb•in)

(1) Maximum/minimum that the terminal block accepts - these are not recommendations.

Vector Control Option I/O Terminal Designations

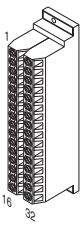

No.	Signal	Factory Default	Description	Related Param.
1	Analog In 1 (-) ⁽¹⁾	⁽⁴⁾	Isolated ⁽⁵⁾ , bipolar, differential, $\pm 10\text{V}/0\text{-}20\text{ mA}$, 11 bit & sign. For 0-20 mA, a jumper must be installed at terminals 17 & 18 (or 19 & 20). 88k ohm input impedance when configured for volt. & 95.3 ohm for current	320 - 327
2	Analog In 1 (+) ⁽¹⁾			
3	Analog In 2 (-) ⁽¹⁾			
4	Analog In 2 (+) ⁽¹⁾			
5	Pot Common	-	For (+) and (-) 10V pot references.	
6	Analog Out 1 (-)	⁽⁴⁾	Single-ended bipolar (current output is not bipolar), $\pm 10\text{V}/0\text{-}20\text{ mA}$, 11 bit & sign, Voltage mode - limit current to 5 mA. Current mode - max. load is 400 ohms.	340 - 347
7	Analog Out 1 (+)			
8	Analog Out 2 (-)			
9	Analog Out 2 (+)			
10	HW PTC Input 1	-	1.8k ohm PTC, Internal 3.32k ohm pull-up resistor	238 259
11	Digital Out 1 – N.C. ⁽²⁾	Fault	Max. Resistive Load: 240V AC/30V DC – 1200VA, 150W Max. Current: 5A, Min. Load: 10 mA	380 - 391
12	Digital Out 1 Common			
13	Digital Out 1 – N.O. ⁽²⁾	NOT Fault	Max. Inductive Load: 240V AC/30V DC – 840VA, 105W Max. Current: 3.5A, Min. Load: 10 mA	
14	Digital Out 2 – N.C. ⁽²⁾	NOT Run		
15	Digital Out 2/3 Com.			
16	Digital Out 3 – N.O. ⁽²⁾	Run		
17	Current In Jumper ⁽¹⁾ – Analog In 1		Placing a jumper across terminals 17 & 18 (or 19 & 20) configures that analog input for current.	320 - 327
18				
19	Current In Jumper ⁽¹⁾ – Analog In 2			
20				
21	-10VDC Pot Ref.	-	2k ohm minimum load.	
22	+10VDC Pot Ref.	-		
23	HW PTC Input 2	-	See above	
24	+24VDC ⁽⁶⁾	-	Drive supplied logic input power. ⁽⁶⁾	
25	Digital In Common	-		
26	24V Common ⁽⁶⁾	-	Common for internal power supply.	
27	Digital In 1 ⁽³⁾	Stop - CF	115V AC, 50/60 Hz - Control & I/O Cat. No. option D Opto isolated Low State: less than 30V AC High State: greater than 100V AC, 5.7 mA	361 - 366
28	Digital In 2 ⁽³⁾	Start		
29	Digital In 3 ⁽³⁾	Auto/Man.	24V DC - Control & I/O Cat. No. option C Opto isolated Low State: less than 5V DC High State: greater than 20V DC, 10 mA DC Digital Input Impedance: 21k ohm	
30	Digital In 4 ⁽³⁾	Speed Sel 1		
31	Digital In 5 ⁽³⁾	Speed Sel 2		
32	Digital In 6/Hardware Enable ⁽³⁾ , see pg. 57	Speed Sel 3		

- (1) **Important:** 0...20 mA operation requires a jumper at terminals 17 & 18 (or 19 & 20). Drive damage can occur if jumper is not installed.
- (2) Contacts in unpowered state. Any relay programmed as Fault or Alarm energizes (picks up) when power is applied to drive and deenergize (drop out) when a fault or alarm exists. Relays selected for other functions energize only when that condition exists and deenergizes when condition is removed.
- (3) A 10k ohm, 2 watt burden resistor must be installed on each digital input when using a triac type device. The resistor is installed between each digital input and neutral /common.
- (4) These inputs/outputs are dependant on a number of parameters (see "Related Parameters").
- (5) Differential Isolation - External source must be maintained at less than 160V with respect to PE. Input provides high common mode immunity.
- (6) 150 mA maximum load designed to power digital inputs only. Not present on 115V versions.

Standard Control Option I/O Terminal Designations



No.	Signal	Factory Default	Description	Related Param.	
1	Anlg Volts In 1 (-)	(2)	Isolated ⁽³⁾ , bipolar, differential, $\pm 10V$, 11 bit & sign, 88k ohm input impedance.	320 - 327	
2	Anlg Volts In 1 (+)				
3	Anlg Volts In 2 (-)	(2)	Isolated ⁽⁴⁾ , bipolar, differential, $\pm 10V$, 11 bit & sign, 88k ohm input impedance.		
4	Anlg Volts In 2 (+)				
5	Pot Common	-	For (+) and (-) 10V pot references.		
6	Anlg Volts Out 1 (-)	(2)	Bipolar, $\pm 10V$, 11 bit & sign, 2k ohm minimum load.	340 - 344	
7	Anlg Volts Out 1 (+)				
8	Anlg Current Out 1 (-)				
9	Anlg Current Out 1 (+)	(2)	4-20mA, 11 bit & sign, 400 ohm maximum load.		
10	Reserved for Future Use				
11	Digital Out 1 – N.C. ⁽¹⁾	Fault	Max. Resistive Load: 240V AC/30V DC – 1200VA, 150W Max. Current: 5A, Min. Load: 10mA Max. Inductive Load: 240V AC/30V DC – 840VA, 105W Max. Current: 3.5A, Min. Load: 10mA	380 - 387	
12	Digital Out 1 Common				
13	Digital Out 1 – N.O. ⁽¹⁾	NOT Fault			
14	Digital Out 2 – N.C. ⁽¹⁾	NOT Run			
15	Digital Out 2 Common				
16	Digital Out 2 – N.O. ⁽¹⁾	Run			
17	Anlg Current In 1 (-)	(2)	Isolated ⁽³⁾ , 4-20 mA, 11 bit & sign, 124 ohm input impedance.	320 - 327	
18	Anlg Current In 1 (+)				
19	Anlg Current In 2 (-)	(2)	Isolated ⁽⁴⁾ , 4-20 mA, 11 bit & sign, 124 ohm input impedance.		
20	Anlg Current In 2 (+)				
21	-10V DC Pot Ref.	-	2k ohm minimum.		
22	+10V DC Pot Ref.	-			
23	Reserved for Future Use				
24	+24V DC ⁽⁵⁾	-	Drive supplied logic input power. ⁽⁵⁾		
25	Digital In Common	-			
26	24V Common ⁽⁵⁾	-	Common for internal power supply.		
27	Digital In 1	Stop - CF	115V AC, 50/60 Hz - Control & I/O Cat. No. option B Opto isolated Low State: less than 30V AC High State: greater than 100V AC, 5.0 mA	361 - 366	
28	Digital In 2	Start			
29	Digital In 3	Auto/Man.	24V AC/DC, 50/60 Hz - Control & I/O Cat. No. option A Opto isolated Low State: less than 5V AC/DC High State: greater than 20V AC/DC 11.2 mA DC Digital Input Impedance: 35k ohm		
30	Digital In 4	Speed Sel 1			
31	Digital In 5	Speed Sel 2			
32	Digital In 6	Speed Sel 3			

- (1) Contacts in unpowered state. Any relay programmed as Fault or Alarm energizes (picks up) when power is applied to drive and deenergize (drop out) when a fault or alarm exists. Relays selected for other functions energize only when that condition exists and deenergizes when condition is removed.
- (2) These inputs/outputs are dependant on a number of parameters. See "Related Parameters."
- (3) Differential Isolation - External source must be maintained at less than 160V with respect to PE. Input provides high common mode immunity.
- (4) Differential Isolation - External source must be less than 10V with respect to PE.
- (5) 150 mA maximum load designed to power digital inputs only. Not present on 115V versions.

I/O Wiring Examples

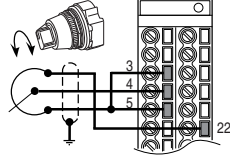
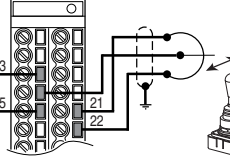
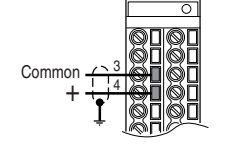
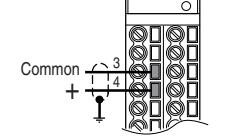
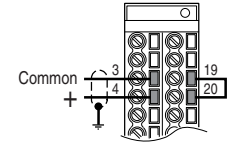
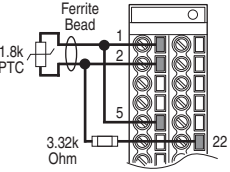
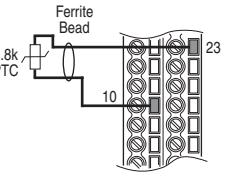
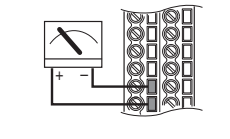
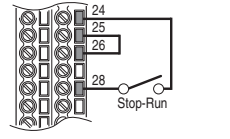
Input/Output	Connection Example	Required Parameter Changes
<p>Potentiometer Unipolar Speed Reference⁽¹⁾ 10k Ohm Pot. Recommended (2k Ohm Minimum)</p>		<ul style="list-style-type: none"> Adjust Scaling: Parameters 91/92 and 325/326 View Results: Parameter 002
<p>Joystick Bipolar Speed Reference⁽¹⁾ ±10V Input</p>		<ul style="list-style-type: none"> Set Direction Mode: Parameter 190 = "1, Bipolar" Adjust Scaling: Parameters 91/92 and 325/326 View Results: Parameter 002
<p>Analog Input Bipolar Speed Reference ±10V Input</p>		<ul style="list-style-type: none"> Set Direction Mode: Parameter 190 = "1, Bipolar" Adjust Scaling: Parameters 91/92 and 325/326 View Results: Parameter 002
<p>Analog Voltage Input Unipolar Speed Reference 0 to +10V Input</p>		<ul style="list-style-type: none"> Configure Input with parameter 320 Adjust Scaling: Parameters 91/92 and 325/326 View results: Parameter 002
<p>Analog Current Input Unipolar Speed Reference 0-20 mA Input</p>		<ul style="list-style-type: none"> Configure Input for Current: Parameter 320 and add jumper at appropriate terminals Adjust Scaling: Parameters 91/92 and 325/326 View results: Parameter 002
<p>Analog Input, PTC PTC OT set > 5V PTC OT cleared < 4V PTC Short < 0.2V</p>		<ul style="list-style-type: none"> Set Fault Config 1: Parameter 238, bit 7 = "Enabled" Set Alarm Config 1: Parameter 259, bit 11 = "Enabled" View Status Drive Alarm 1: Parameter 211, bit 11 = "True"
<p>HW PTC Input PTC OT set > 5V PTC OT cleared < 4V PTC Short < 0.2V</p>		<ul style="list-style-type: none"> Set Fault Config 1: Parameter 238, bit 13 = "Enabled" Set Alarm Config 1: Parameter 259, bit 18 = "Enabled" View Status: Drive Alarm 1: Parameter 211, bit 18 = "True"
<p>Analog Output ±10V, 0-20 mA Bipolar +10V Unipolar (shown)</p>		<ul style="list-style-type: none"> Configure with Parameter 340 Select Source Value: Parameter 380, [Digital Out1 Sel] Adjust Scaling: Parameters 343/344
<p>2-Wire Control Non-Reversing⁽²⁾ 24V DC internal supply</p>		<ul style="list-style-type: none"> Disable Digital Input:#1: Parameter 361 = "0, Unused" Set Digital Input #2: Parameter 362 = "7, Run" Set Direction Mode: Parameter 190 = "0, Unipolar"

Input/Output	Connection Example	Required Parameter Changes
2-Wire Control Reversing⁽¹⁾ External supply (I/O Board dependent)		<ul style="list-style-type: none"> Set Digital Input:#1: Parameter 361 = "8, Run Forward" Set Digital Input #2: Parameter 362 = "9, Run Reverse"
3-Wire Control Internal supply		<ul style="list-style-type: none"> No Changes Required
3-Wire Control External supply (I/O Board dependent). Requires 3-wire functions only ([Digital In1 Sel]). Using 2-wire selections causes a type 2 alarm.		<ul style="list-style-type: none"> No Changes Required
Digital Input PLC Output Card (Board dependent).		<ul style="list-style-type: none"> No Changes Required
Digital Output Relays (two at terminals 14...16) shown in powered state with drive faulted. See page 54 and page 55 .		<ul style="list-style-type: none"> Select Source to Activate: Parameters 380/384
Enable Input		<ul style="list-style-type: none"> Configure with parameter 366 For dedicated hardware Enable: Remove Jumper J10 (see below)

(1) Refer to the Attention statement on [page 52](#) for important bipolar wiring information.

(2) **Important:** Programming inputs for 2 wire control deactivates all HIM Start buttons unless parameter 192, [Save HIM Ref], bit 1 [Manual Mode] = "1." This allows the HIM to control Start and Jog.

Hardware Enable Circuitry (Vector Control Only)

By default, the user can program a digital input as an Enable input. The status of this input is interpreted by drive software. If the application requires the drive to be disabled without software interpretation, a "dedicated" hardware enable configuration can be utilized. This is done by removing a jumper and wiring the enable input to "Digital In 6."

- Remove the I/O Control Cassette & cover as described on [page 53](#).
- Locate & remove Jumper J10 on the Main Control Board (see diagram).
- Re-assemble cassette.
- Wire Enable to "Digital In 6" (see [page 54](#)).
- Verify that [Digital In6 Sel], parameter 366 is set to "1, Enable."

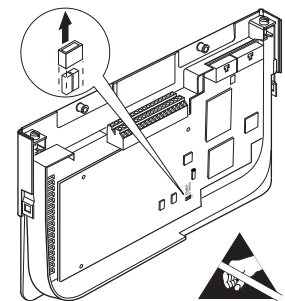

Encoder Interface Option (Vector Control Only)

Encoder Terminal Designations

No.	Description	
8	+12V ⁽¹⁾ DC Power	Internal power source 250 mA.
	+12V ⁽¹⁾ DC Return (Common)	
6	Encoder Z (NOT)	Pulse, marker or registration input. ⁽²⁾
5	Encoder Z	
4	Encoder B (NOT)	Quadrature B input.
3	Encoder B	
2	Encoder A (NOT)	Single channel or quadrature A input.
1	Encoder A	

See "Detail" on [page 53](#)

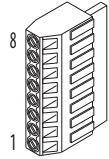

- (1) Jumper selectable +5/12V is available on 20B-ENC-1 Encoder Boards.
- (2) Z channel can be used as a pulse input while A & B are used for encoder.

Encoder Specifications

Type:	Incremental, dual channel
Supply:	12V, 250 mA. 12V, 10 mA minimum inputs isolated with differential transmitter, 250 kHz maximum.
Quadrature:	90°, ±27 degrees at 25 degrees C.
Duty Cycle:	50%, +10%
Requirements:	Encoders must be line driver type, quadrature (dual channel) or pulse (single channel), 8...15V DC output (3.5...6V DC when jumpers are in 5V position), single-ended or differential and capable of supplying a minimum of 10 mA per channel. Maximum input frequency is 250 kHz. The Encoder Interface Board accepts 12V DC square-wave with a minimum high state voltage of 7.0V DC. With the jumpers in the 5V position, the encoder accept a 5V DC square-wave with a minimum high state voltage of 3.1V DC. In either jumper position, the maximum low state voltage is 0.4V DC.

Encoder Board Jumper Settings

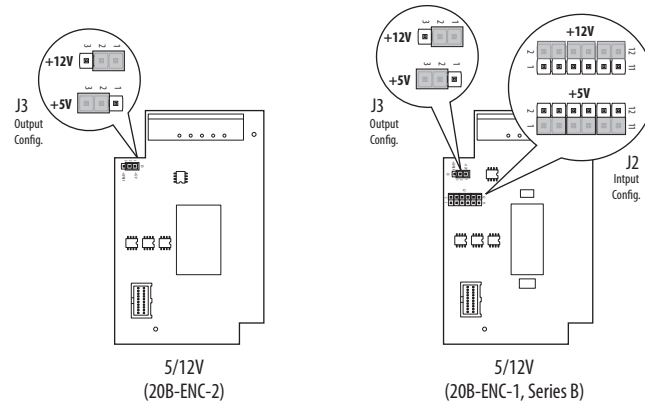

Sample Encoder Wiring

I/O	Connection Example	I/O	Connection Example
Encoder Power – Internal Drive Power Internal (drive) 12V DC, 250mA ⁽¹⁾		Encoder Power – External Power Source	
Encoder Signal – Single-Ended, Dual Channel ⁽²⁾		Encoder Signal – Differential, Dual Channel	

(1) SHLD connection is on drive chassis (see [page 29](#)).

(2) Example applies to 20B-ENC-1 only.

Reference Control

Auto Speed Sources

The drive speed command can be obtained from a number of different sources. The source is determined by drive programming and the condition of the Speed Select digital inputs, Auto/Manual digital inputs or reference select bits of a command word.

The default source for a command reference (all speed select inputs are open—the default setting) is the selection programmed in [Speed Ref A Sel]. If any of the speed select inputs are closed, other parameters are used as the speed command source.

Manual Speed Sources

The manual source for speed command to the drive can be selected several ways:

- The HIM can provide the manual source when:
 - manual control is requested from the HIM (see [ALT Functions](#) on [page 67](#))
 - or ...
 - the I/O terminal block requests manual control through a digital input programmed for “Auto/Manual.” [TB Man Ref Sel] is then set to one of the DPI ports with a HIM connected to it. ⁽¹⁾
- The I/O terminal block analog input can provide the manual source when a digital input is programmed for “Auto/Manual” when active. [TB Man Ref Sel] is set to “Analog Input.”

(1) Requires drive firmware v7.001 or greater and a Series B HIM with firmware v5.004 or greater.

Changing Speed Sources

The selection of the active Speed Reference can be made through digital inputs, DPI command, jog button or Auto/Manual HIM operation.

Torque Reference Source

The torque reference is normally supplied by an analog input or network reference. Switching between available sources while the drive is running is not available. Digital inputs programmed as “Speed Sel 1,2,3” and the HIM Auto/Manual function (see above) do not affect the active torque reference when the drive is in Vector Control Mode.

Speed Reference Selection Chart (1)

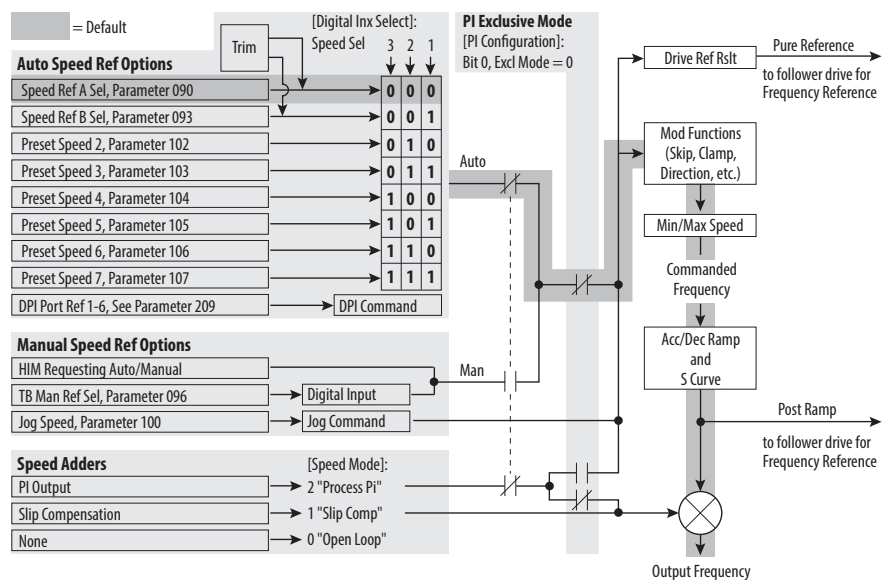

Auto/Manual Examples

PLC = Auto, HIM = Manual

A process is run by a PLC when in Auto mode and requires manual control from the HIM during set-up. The Auto speed reference is issued by the PLC through a communications module installed in the drive. Since the internal communications is designated as Port 5, [Speed Ref A Sel] is set to “DPI Port 5” with the drive running from the Auto source.

- Attain Manual Control
 - Press ALT then Auto/Man on the HIM. When the HIM attains manual control, the drive speed command comes from the HIM speed control keys.
- Release to Auto Control
 - Press ALT then Auto/Man on the HIM again. When the HIM releases manual control, the drive speed command returns to the PLC.

(1) To access Preset Speed 1, set parameter 090 or 093 to “Preset Speed 1.”

PLC = Auto, Terminal Block = Manual

A process is run by a PLC when in Auto mode and requires manual control from an analog potentiometer wired to the drive terminal block. The auto speed reference is issued by the PLC through a communications module installed in the drive. Since the internal communications is designated as Port 5, [Speed Ref A Sel] is set to “DPI Port 5” with the drive running from the Auto source. Since the Manual speed reference is issued by an analog input (“Analog In 1 or 2”), [TB Man Ref Sel] is set to the same input. To switch between Auto and Manual, [Digital In3 Sel] is set to “Auto/Manual.”

- Attain Manual Control
 - Close the digital input.
With the input closed, the speed command comes from the pot.
- Release to Auto Control
 - Open the digital input.
With the input open, the speed command returns to the PLC.

PLC = Auto, Terminal Block = Manual, with speed reference from the HIM

IMPORTANT Requires drive firmware v7.001 or greater and a Series B HIM with firmware v5.004 or greater.

A process is run by a PLC when in Auto mode and requires manual control from the terminal block with the speed reference provided by the HIM.

The auto speed reference is produced by the PLC and transmitted to the drive through a communications module installed in the drive. Since the internal communications is designated as Port 5, [Speed Ref A Sel] is set to “DPI Port 5” with the drive running from the Auto source.

When Manual mode is requested through the terminal block digital input, the drive evaluates if Manual mode can be granted.

If [TB Man Ref Sel], parameter 96 is set to a DPI Port and [Man Ref Preload], parameter 193 is enabled, the drive transfers the last value of the automatic speed reference to the HIM. The HIM is now the speed reference source. The terminal block has exclusive control based on [Save HIM Ref], parameter 192, bit 1 (Manual Mode).

If [TB Man Ref Sel] is set to a DPI Port and [Man Ref Preload] is disabled, the HIM is now the speed reference source. The terminal block has exclusive control based on [Save HIM Ref], bit 1 (Manual Mode).

If [TB Man Ref Sel] is set to one of the DPI Ports, a HIM must be connected on the DPI Port selected.

IMPORTANT The HIM does not enter Manual mode, it is only the reference source for the terminal block.

- Attain Manual Control
 - Close the digital input.
With the input closed, the speed command comes from the HIM.
- Release to Auto Control
 - Open the digital input.
With the input open, the speed command returns to the PLC.

Auto/Manual Notes

1. Manual control is exclusive. If a HIM or terminal block takes manual control, no other device can take manual control until the controlling device releases manual control.
2. If a HIM has manual control and power is removed from the drive, the drive returns to Auto mode when power is reapplied.
3. Parameter 192 - [Save HIM Ref], bit 1 can enable Manual mode to allow starts and jogs from the HIM in 2-wire mode.

Step 5: Start-Up Check List

- This check list supports the Basic Start-Up menu option. See [page 67](#) for information on other start-up routines.
- A Human Interface Module (HIM) is required to run the Basic Start-Up routine.
- The Basic Start-Up routine can modify parameter values for Analog and Digital I/O. Refer to Common I/O Programming Changes on [page 71](#).



ATTENTION: Power must be applied to the drive to perform the following start-up procedure. Some of the voltages present are at incoming line potential. To avoid electric shock hazard or damage to equipment, only qualified service personnel must perform the following procedure. Thoroughly read and understand the procedure before beginning.

Prepare For Drive Start-Up

1. Confirm that all inputs are connected to the correct terminals and are secure.
2. Verify that AC line power at the disconnect device is within the rated value of the drive.
3. Verify that control power voltage is correct.
4. The remainder of this procedure requires that a HIM be installed. Connect a Human Interface Module (HIM) to Drive Peripheral Interface (DPI) Port 1 or 2. Use remote devices to start up the drive, if an operator interface is not available.

DPI Ports ① and ②



IMPORTANT When power is first applied, the HIM can require approximately 5 seconds until commands are recognized (including the Stop key). An explanation of the LED indicators can be found on page 75.

5. Apply AC power and control voltages to the drive.

If any of the six digital inputs are configured to “Stop – CF” (CF = Clear Fault) or “Enable,” verify that signals are present or reconfigure [Digital Inx Sel], parameters 361...366. If an I/O option is not installed (i.e. no I/O terminal block), verify that [Digital Inx Sel] is not configured to “Stop – CF” or “Enable.” If this is not done, the drive does not start. Refer to [Abbreviated Fault Listing](#) on [page 72](#) for a list of potential digital input conflicts.

If the STS LED is not flashing green at this point, refer to [Drive Status Indicators](#) on [page 70](#).

6. When prompted, select a display language. The PowerFlex 700 Start-Up Screen displays.
7. Press the Enter key to display the Start-Up Menu.
8. Use the Arrow keys to highlight “2. Basic”.
9. Press the Enter key. Follow the menu by using the Enter key to step you through the Start-Up routine.

The Basic Start-Up routine asks simple questions and prompts you to input required information. See also [Common I/O Programming Changes](#) on [page 71](#).

Information About Start-Up Motor Tests

Control schemes vary based on the Start/Jog Source selected in Step 3. Motor Tests.

Start/Jog Source	Control Source Description
Digital Inputs	Digital In 1 = Stop / Digital In 2 = Start / Digital In 3 = Jog
Local Human Interface Module (HIM)–Port 1	Human Interface Module (HIM) connected to DPI Port 1 controls Stop / Start / Jog Digital In 1...6 are temporarily disabled during motor tests.
Remote HIM	Human Interface Module (HIM) connected to DPI Port 2 controls Stop / Start / Jog Digital In 1...6 are temporarily disabled during motor tests.

During motor tests and tuning procedures, the drive can modify certain parameter values for proper Start Up operation. These values are then reset to their original values when Start Up is complete. The affected parameters are: 053, 080, 276, 278 and 361...366. If power is removed from the drive during the tests without aborting the auto-tune procedure, these parameters can not reset to their original value. If this situation occurs, reset the drive to factory defaults (see [page 71](#)) and repeat the Start Up procedure.

First Powerup Menu Structure

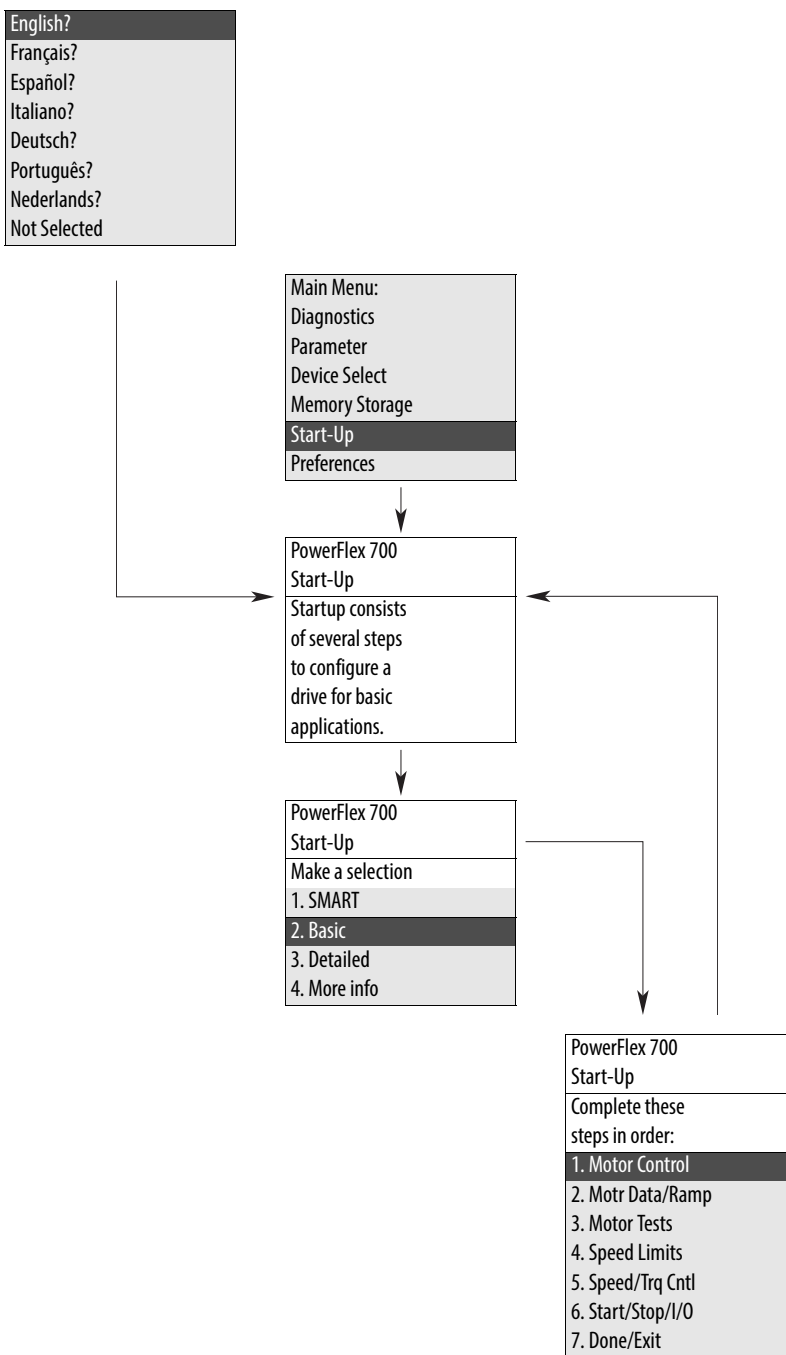

Supplemental Information Using PowerFlex Drives w/Regen Units

If a Regenerative unit (for example, 1336 REGEN) is used as a bus supply or brake, the common mode capacitors must be disconnected as described on [page 43](#).

Connections to the 1336 REGEN

Regen Brake Mode

Frame(s)	Terminals	
	1336 REGEN	PowerFlex 700
0...4	DC+	BR1
	DC-	DC-
5...6	DC+	DC+
	DC-	DC-

Regenerative Bus Supply Mode

Frame(s)	Terminals	
	1336 REGEN	PowerFlex 700
0...4	DC+	DC+
	DC-	DC-
5...6	DC+	DC+ of Common Bus Drives
	DC-	DC- of Common Bus Drives

DC Input (Common Bus) and Precharge Notes

The following notes must be read and understood. Also refer to pages [26](#) through [30](#) for additional DC input information.

Important Application Notes







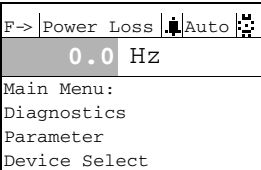





1. If drives without internal precharge are used (Frames 5 & 6 only), then:
 - a. precharge capability must be provided in the system to guard against possible damage, and
 - b. disconnect switches **Must Not** be used between the input of the drive and a common DC bus without the use of an external precharge device.
2. If drives with internal precharge (Frames 0...6) are used with a disconnect switch to the common bus, then:
 - a. an auxiliary contact on the disconnect must be connected to a digital input of the drive. The corresponding input (parameter 361...366) must be set to “30, Precharge Enable.” This provides the proper precharge interlock, guarding against possible damage to the drive when connected to a common DC bus.
 - b. the drive must have firmware version 2.002 or above.

Human Interface Module (HIM) Overview

LCD Display Elements

Display	Description
 <p>F-> Power Loss Auto M 0.0 Hz Main Menu: Diagnostics Parameter Device Select</p>	Direction Drive Status Alarm Auto/Man Information Commanded or Output Frequency Programming / Monitoring / Troubleshooting

Human Interface Module (HIM) Key Functions

Key	Description
	Exit a menu, cancel a change to a parameter value, or acknowledge a fault/alarm.
	Select a digit, select a bit, or enter edit mode in a parameter screen.
	Scroll through options, increase a value, or toggle a bit.
	Scroll through options, decrease a value, or toggle a bit.
	Enter a menu, enter edit mode in a parameter screen, or save a change to a parameter value.
	Access the function associated with a programming or numeric key. Refer to the drive user manual for more information.
	Start the drive.
	Stop the drive or clear a fault.
	Jog the drive.
	Change direction.
	Increase speed.
	Decrease speed.

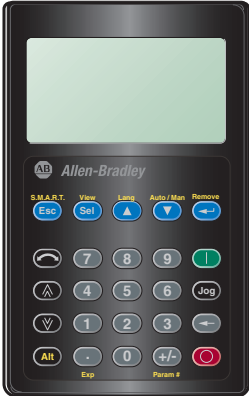

Human Interface Module (HIM)





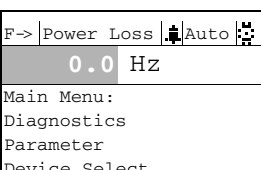



These keys are active only when the HIM is granted Manual Control or Param. 090 [Speed Ref A Sel] / 093 [Speed Ref B Sel] is set to:
 Option 18 "DPI Port 1" for a HIM installed in the drive cover
 or
 Option 19 "DPI Port 2" for a HIM connected by cable for handheld or remote installation option

Human Interface Module (HIM) Main Menu

Main Menu Screen	Menu Selections
 <p>F-> Power Loss Auto M 0.0 Hz Main Menu: Diagnostics Parameter Device Select</p>	Main Menu: Diagnostics Parameter Device Select Memory Storage Start-Up Preferences

ALT Functions

To use an ALT function, start at the Main Menu and press the ALT key, release it, then press the programming key associated with one of the following functions:

ALT Key then	Function	Function Description
	S.M.A.R.T.	Displays the S.M.A.R.T. screen. This function allows the drive parameter values to be quickly programmed by directly accessing the most frequently used drive functions. Refer to the User Manual for more information.
	Log In/Out	Log in to change parameter settings. Log out to protect parameter settings. Change a password.
	View	Allows the selection of how parameters are viewed or detailed information about a parameter or component.
 	Device	Select a connected adapter for editing.
	Lang	Displays the language selection screen. The LCD Human Interface Module (HIM) on an architecture class drive allows you to change the display language any time.
	Auto / Man	Switches between Auto and Manual Modes. If the Human Interface Module (HIM) requests Manual Mode, the Speed Reference source is transferred to the Human Interface Module (HIM).
	Remove	Allows Human Interface Module (HIM) removal without causing a fault if the Human Interface Module (HIM) is not the last controlling device and does not have Manual control of the drive.
	Param #	Allows entry of a parameter number for viewing/editing.

Start-Up Routines

The PowerFlex 700 start up routines allow the user to commission the drive more quickly and accurately. If you have an LCD HIM, two methods are provided.

- **S.M.A.R.T. Start**

This routine is accessible by using the “ALT” function key on the LCD HIM. This keystroke brings up a list of parameters needed to program the eight most commonly adjusted drive functions. These include Start, Stop, Minimum Speed, Maximum Speed, Acceleration Time, Deceleration Time, Reference source (speed command) and Electronic Overload setting for the motor. No knowledge of parameter organization or access is required. S.M.A.R.T. Start can commission the drive in just a few minutes. See [page 69](#).

- **Assisted Start Up**

Three levels of Assisted Start Up (Basic, Detailed and Application) aid the user in commissioning the drive asking simple Yes/No or “Enter Data” questions. The user is guided through the Start Up to reduce the amount of time necessary to get the drive “up and running.” The following are included in startup:

- Input Voltage Ratings
- Motor Data
- Motor Tests & Auto-tuning
- Speed/Torque Control & Direction Limits
- Speed Reference
- Start & Stop Modes
- Ramp Setup
- Digital and Analog I/O
- Application Set-up (TorqProve, Oil Well Pumps, Positioning/Speed Profiling)

See [page 70](#) for details.

IMPORTANT Power must be applied to the drive when viewing or changing parameters. Previous programming can affect the drive status and operation when power is applied. If the I/O Cassette has been changed, a Reset Defaults operation must be performed.

Torque Proving applications can use the Assisted Start Up to tune the motor. However, it is recommended that the motor be disconnected from the hoist/crane equipment during the routine. If this is not possible, refer to the manual tuning procedure in the User Manual.

Start Up Menu

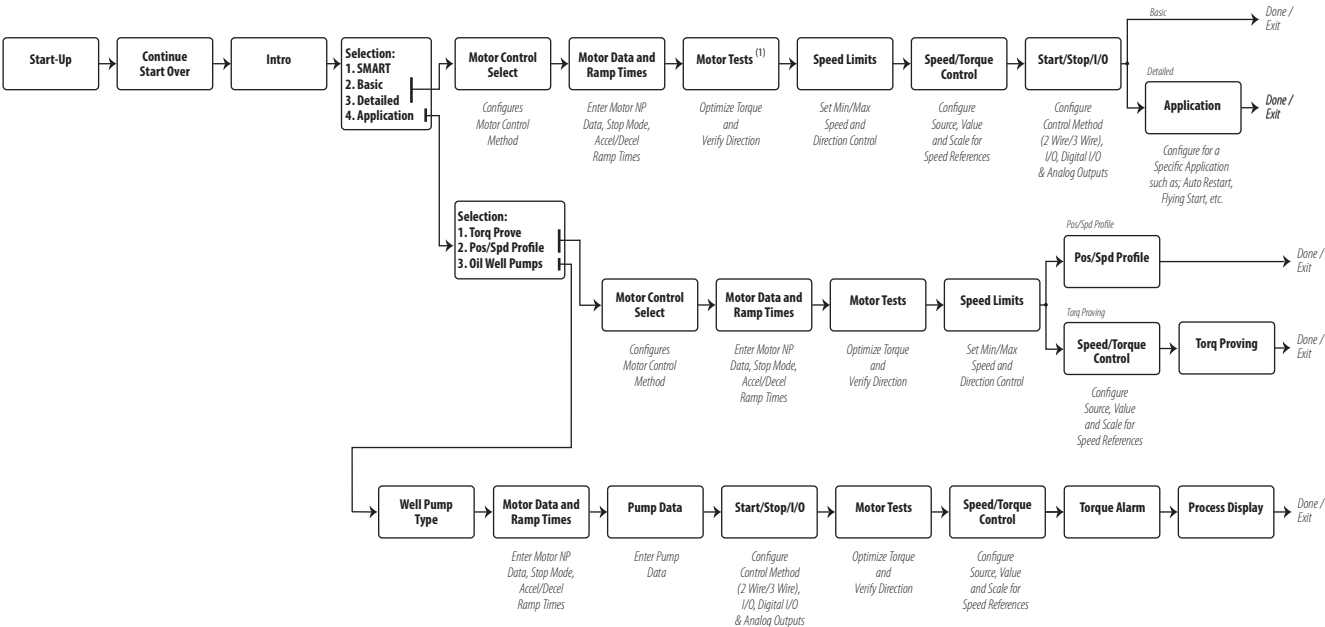

(1) During Motor Tests and tuning procedures, the drive can modify certain parameter values for proper Start Up operation. These values are then reset to their original values when Start Up is complete. The affected parameters are: 053, 080, 276, 278 and 361...366. If power is removed from the drive during the tests without aborting the auto-tune procedure, these parameters can not be reset to their original value. If this situation occurs, reset the drive to factory defaults and repeat the Start Up procedure.

Running S.M.A.R.T. Start

During a Start Up, the majority of applications require changes to a few parameters. The LCD HIM on a PowerFlex 700 drive offers S.M.A.R.T. start, which displays the most commonly changed parameters. With these parameters, you can set the following functions:

- S - Start Mode and Stop Mode
- M - Minimum and Maximum Speed
- A - Accel Time 1 and Decel Time 1
- R - Reference Source
- T - Thermal Motor Overload

To run a S.M.A.R.T. start routine:

Step	Key(s)	Example LCD Displays
1. Press ALT and then Esc (S.M.A.R.T.). The S.M.A.R.T. start screen appears.	ALT Esc	F-> Stopped Auto
2. View and change parameter values as desired. For HIM information, see Appendix B in the User Manual.		SMART List: Digital In2 Sel Stop Mode A Minimum Speed
3. Press Esc to exit the S.M.A.R.T. start.	Esc	

Running an Assisted Start Up

IMPORTANT This start-up routine requires an LCD HIM.

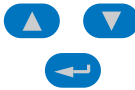
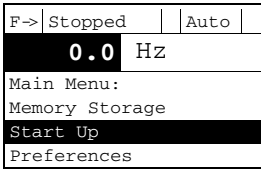

The Assisted start-up routine prompts you to input required information. Access Assisted Start Up by selecting “Start Up” from the Main Menu.

To perform an Assisted Start-Up

Step	Key(s)	Example LCD Displays
1. In the Main Menu, press the Up Arrow or Down Arrow to scroll to “Start Up”. 2. Press Enter.		

IMPORTANT Done/Exit must be selected upon completion of the Start Up routine in order for any Start Up/Autotune data to be saved.

Drive Status Indicators

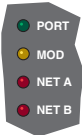
Name	Color	State	Description
	Green	Steady	Illuminates when power is applied to the drive.
	Green	Flashing	Drive ready, but not running and no faults are present.
		Steady	Drive running, no faults are present.
	Yellow	Flashing, Drive Stopped	An inhibit condition exists, the drive cannot be started. Check parameter 214 [Start Inhibits].
		Flashing, Drive Running	An intermittent type 1 alarm condition is occurring. Check parameter 211 [Drive Alarm 1].
		Steady, Drive Running	A continuous type 1 alarm condition exists. Check parameter 211 [Drive Alarm 1].
	Red	Flashing	A fault has occurred.
Steady		A non-resettable fault has occurred.	
	Refer to the Communication Adapter User Manual.		Status of DPI port internal communications (if present).
			Status of communications module (when installed).
			Status of network (if connected).
			Status of secondary network (if connected).

Common I/O Programming Changes

Your application needs may require changing parameters from their factory default settings.

Speed Reference A

Change Speed Reference A from Analog In 2 to Analog In 1 to connect an external potentiometer.

1. Set Param. 090 [Speed Ref A Sel] to option 1 “Analog In 1”
This sets the speed reference input to I/O terminals 1 & 2. For 4...20 mA operation, a jumper must be placed between terminals 17 & 18.
2. Set Param. 096 [TB Man Ref Sel] to option 9 “MOP Level”
This eliminates a potential Conflict alarm condition. Analog In 2 is not a valid Speed Reference source if selected for any of the following:
 - 117 [Trim In Select]
 - 126 [PI Reference Sel]
 - 128 [PI Feedback Sel]
 - 147 [Current Lmt Sel]
 - 179 [Sleep-Wake Ref]
3. Set Param. 091 [Speed Ref A Hi] to the upper value of the desired speed reference range in Hz
4. Set Param. 092 [Speed Ref A Lo] to the lower value of the desired speed reference range in Hz

Control Scheme

Change from 3 Wire Start/Stop to 2 Wire Run/Not Run at Digital In 1 & Digital In 2.

IMPORTANT This disables the Start button on the HIM.

1. Set Param. 361 [Digital In1 Sel] to option 7 “Run” or 9 “Run Reverse”
2. Set Param. 362 [Digital In2 Sel] to another option such as 8 “Run Forward” or 10 “Jog”

See I/O Wiring Examples beginning on [page 56](#).

Restoring Factory Defaults

From the Human Interface Module (HIM) Main Menu select: Memory Storage / Reset To Defaults

Troubleshooting

For a complete listing of Faults and Alarms, refer to the PowerFlex 700 User Manual, publication [20B-UM002](#).

Table 10 - Abbreviated Fault Listing

Fault	No.	Type ⁽¹⁾	Description	Action
Auxiliary Input	2	①	Auxiliary input interlock is open.	Check remote wiring.
Decel Inhibit	24	③	The drive is not following a commanded deceleration because it is attempting to limit bus voltage.	<ol style="list-style-type: none"> 1. Verify input voltage is within drive specified limits. 2. Verify system ground impedance follows proper grounding techniques. 3. Disable bus regulation and/or add dynamic brake resistor and/or extend deceleration time. Refer to page 6 for further info. 4. Disable with parameter 238.
FluxAmpsRef Rang	78		The value for flux amps determined by the Autotune procedure exceeds the programmed [Motor NP FLA], parameter 042.	<ol style="list-style-type: none"> 1. Reprogram [Motor NP FLA] with the correct motor nameplate value. 2. Repeat Autotune.
HW OverCurrent	12	①	The drive output current has exceeded the hardware current limit.	Check programming. Check for excess load, improper DC boost setting, DC brake volts set too high or other causes of excess current.
IR Volts Range	77		"Calculate" is the autotune default and the value determined by the autotune procedure for IR Drop Volts is not in the range of acceptable values.	Re-enter motor nameplate data.
Motor Overload	7	① ③	Internal electronic overload trip. Enable/Disable with [Fault Config 1].	An excessive motor load exists. Reduce load so drive output current does not exceed the current set by [Motor NP FLA].
OverSpeed Limit	25	①	Functions such as Slip Compensation or Bus Regulation have attempted to add an output frequency adjustment greater than that programmed in [Overspeed Limit], parameter 083.	Remove excessive load or overhauling conditions or increase [Overspeed Limit].
OverVoltage	5	①	DC bus voltage exceeded maximum value.	Monitor the AC line for high line voltage or transient conditions. Bus overvoltage can also be caused by motor regeneration. Extend the decel time or install dynamic brake option.
SW OverCurrent	36	①	Drive output current has exceeded the 1ms current rating. This rating is greater than the 3 second current rating and less than the hardware overcurrent fault level. It is typically 200...250% of the drive continuous rating.	Check for excess load, improper DC boost setting, DC brake volts set too high.

(1) See the User Manual for a description of fault types.

Table 11 - Abbreviated Alarm Listing

Alarm	No.	Type ⁽¹⁾	Description																																																																																																				
Dig In ConflictA	17	②	Digital input functions are in conflict. Combinations marked with a "⚡" cause an alarm.																																																																																																				
			<table border="1"> <thead> <tr> <th></th> <th>Acc2/Dec2</th> <th>Accel 2</th> <th>Decel 2</th> <th>Jog 1/2</th> <th>Jog Fwd</th> <th>Jog Rev</th> <th>Fwd/Rev</th> </tr> </thead> <tbody> <tr> <td>Acc2/Dec2</td> <td></td> <td>⚡</td> <td>⚡</td> <td></td> <td></td> <td></td> <td></td> </tr> <tr> <td>Accel 2</td> <td>⚡</td> <td></td> <td></td> <td></td> <td></td> <td></td> <td></td> </tr> <tr> <td>Decel 2</td> <td>⚡</td> <td></td> <td></td> <td></td> <td></td> <td></td> <td></td> </tr> <tr> <td>Jog 1/2</td> <td></td> <td></td> <td></td> <td></td> <td>⚡</td> <td>⚡</td> <td></td> </tr> <tr> <td>Jog Fwd</td> <td></td> <td></td> <td></td> <td>⚡</td> <td></td> <td></td> <td>⚡</td> </tr> <tr> <td>Jog Rev</td> <td></td> <td></td> <td></td> <td>⚡</td> <td></td> <td></td> <td>⚡</td> </tr> <tr> <td>Fwd/Rev</td> <td></td> <td></td> <td></td> <td></td> <td>⚡</td> <td>⚡</td> <td></td> </tr> </tbody> </table>		Acc2/Dec2	Accel 2	Decel 2	Jog 1/2	Jog Fwd	Jog Rev	Fwd/Rev	Acc2/Dec2		⚡	⚡					Accel 2	⚡							Decel 2	⚡							Jog 1/2					⚡	⚡		Jog Fwd				⚡			⚡	Jog Rev				⚡			⚡	Fwd/Rev					⚡	⚡																																					
				Acc2/Dec2	Accel 2	Decel 2	Jog 1/2	Jog Fwd	Jog Rev	Fwd/Rev																																																																																													
			Acc2/Dec2		⚡	⚡																																																																																																	
			Accel 2	⚡																																																																																																			
			Decel 2	⚡																																																																																																			
			Jog 1/2					⚡	⚡																																																																																														
			Jog Fwd				⚡			⚡																																																																																													
Jog Rev				⚡			⚡																																																																																																
Fwd/Rev					⚡	⚡																																																																																																	
Dig In ConflictB	18	②	A digital Start input has been configured without a Stop input or other functions are in conflict. Combinations that conflict are marked with a "⚡" and cause an alarm.																																																																																																				
			<table border="1"> <thead> <tr> <th></th> <th>Start</th> <th>Stop-CF</th> <th>Run</th> <th>Run Fwd</th> <th>Run Rev</th> <th>Jog 1/2</th> <th>Jog Fwd</th> <th>Jog Rev</th> <th>Fwd/Rev</th> </tr> </thead> <tbody> <tr> <td>Start</td> <td></td> <td></td> <td>⚡</td> <td>⚡</td> <td>⚡</td> <td></td> <td>⚡</td> <td>⚡</td> <td></td> </tr> <tr> <td>Stop-CF</td> <td></td> <td></td> <td></td> <td></td> <td></td> <td></td> <td></td> <td></td> <td></td> </tr> <tr> <td>Run</td> <td>⚡</td> <td></td> <td></td> <td>⚡</td> <td>⚡</td> <td></td> <td>⚡</td> <td>⚡</td> <td></td> </tr> <tr> <td>Run Fwd</td> <td>⚡</td> <td></td> <td>⚡</td> <td></td> <td></td> <td>⚡</td> <td></td> <td></td> <td>⚡</td> </tr> <tr> <td>Run Rev</td> <td>⚡</td> <td></td> <td>⚡</td> <td></td> <td></td> <td>⚡</td> <td></td> <td></td> <td>⚡</td> </tr> <tr> <td>Jog 1/2</td> <td></td> <td></td> <td></td> <td>⚡</td> <td>⚡</td> <td></td> <td></td> <td></td> <td></td> </tr> <tr> <td>Jog Fwd</td> <td>⚡</td> <td></td> <td>⚡</td> <td></td> <td></td> <td></td> <td></td> <td></td> <td></td> </tr> <tr> <td>Jog Rev</td> <td>⚡</td> <td></td> <td>⚡</td> <td></td> <td></td> <td></td> <td></td> <td></td> <td></td> </tr> <tr> <td>Fwd/Rev</td> <td></td> <td></td> <td></td> <td>⚡</td> <td>⚡</td> <td></td> <td></td> <td></td> <td></td> </tr> </tbody> </table>		Start	Stop-CF	Run	Run Fwd	Run Rev	Jog 1/2	Jog Fwd	Jog Rev	Fwd/Rev	Start			⚡	⚡	⚡		⚡	⚡		Stop-CF										Run	⚡			⚡	⚡		⚡	⚡		Run Fwd	⚡		⚡			⚡			⚡	Run Rev	⚡		⚡			⚡			⚡	Jog 1/2				⚡	⚡					Jog Fwd	⚡		⚡							Jog Rev	⚡		⚡							Fwd/Rev				⚡	⚡				
				Start	Stop-CF	Run	Run Fwd	Run Rev	Jog 1/2	Jog Fwd	Jog Rev	Fwd/Rev																																																																																											
			Start			⚡	⚡	⚡		⚡	⚡																																																																																												
			Stop-CF																																																																																																				
			Run	⚡			⚡	⚡		⚡	⚡																																																																																												
			Run Fwd	⚡		⚡			⚡			⚡																																																																																											
			Run Rev	⚡		⚡			⚡			⚡																																																																																											
Jog 1/2				⚡	⚡																																																																																																		
Jog Fwd	⚡		⚡																																																																																																				
Jog Rev	⚡		⚡																																																																																																				
Fwd/Rev				⚡	⚡																																																																																																		
Dig In ConflictC	19	②	More than one physical input has been configured to the same input function. Multiple configurations are not allowed for the following input functions. Forward/Reverse Run Reverse Bus Regulation Mode B Speed Select 1 Jog Forward Acc2 / Dec2 Speed Select 2 Jog Reverse Accel 2 Speed Select 3 Run Decel 2 Run Forward Stop Mode B																																																																																																				
TB Man Ref Cfct	30	②	Occurs when: <ul style="list-style-type: none"> • "Auto/Manual" is selected (default) for [Digital In3 Sel], parameter 363 <i>and</i> • [TB Man Ref Sel], parameter 96 has been reprogrammed. No other use for the selected analog input can be programmed. Example: If [TB Man Ref Sel] is reprogrammed to "Analog In 2," all of the factory default uses for "Analog In 2" must be reprogrammed (such as parameters 90, 117, 128 and 179). Refer to the Auto/Manual Examples section of the PowerFlex 700 User Manual. To correct: <ul style="list-style-type: none"> • Verify/reprogram the parameters that reference an analog input <u>or</u> • Reprogram [Digital In3] to another function or "Unused." 																																																																																																				

(1) See the User Manual for a description of alarm types.

Common Symptoms and Corrective Actions

Drive does not Start from Start or Run Inputs wired to the terminal block.

Cause(s)	Indication	Corrective Action
Drive is Faulted	Flashing red status light	Clear fault. <ul style="list-style-type: none"> • Press Stop • Cycle power • Set [Fault Clear] to 1 • "Clear Faults" on the HIM Diagnostic menu.
Incorrect input wiring. Refer to the wiring examples starting on page 56 . <ul style="list-style-type: none"> • 2 wire control requires Run, Run Forward, Run Reverse or Jog input. • 3 wire control requires Start and Stop inputs. • Jumper from terminal 25 to 26 is required. 	None	Wire inputs correctly and/or install jumper.
Incorrect digital input programming. <ul style="list-style-type: none"> • Mutually exclusive choices have been made (i.e., Jog and Jog Forward). • 2 wire and 3 wire programming can be conflicting. • Exclusive functions (i.e, direction control) can have multiple inputs configured. • Stop is factory default and is not wired. 	None	Program [Digital Inx Sel], parameters 361...366 for correct inputs. Start or Run programming can be missing.
	Flashing yellow status light and "DigIn CflctB" indication on LCD HIM. [Drive Status 2] shows type 2 alarm(s).	Program [Digital Inx Sel] to resolve conflicts. Remove multiple selections for the same function. Install stop button to apply a signal at stop terminal.

Drive does not Start from Human Interface Module (HIM).

Cause(s)	Indication	Corrective Action
Drive is programmed for 2 wire control. HIM Start button is disabled for 2 wire control unless param. 192, bit 1 = "1."	None	If 2 wire control is required, no action needed. If 3 wire control is required, program [Digital Inx Sel] for correct inputs.

Drive does not respond to changes in speed command.

Cause(s)	Indication	Corrective Action
No value is coming from the source of the command.	LCD HIM Status Line indicates "At Speed" and output is 0 Hz.	<ol style="list-style-type: none"> 1. If the source is an analog input, check wiring and use a meter to check for presence of signal. 2. Check [Commanded Speed], parameter 002 for correct source.
Incorrect reference source has been programmed.	None	<ol style="list-style-type: none"> 3. Check parameter 213, [Speed Ref Source] for the source of the speed reference. 4. Reprogram parameter 090, [Speed Ref A Sel] for correct source.
Incorrect Reference source is being selected via remote device or digital inputs.	None	<ol style="list-style-type: none"> 5. Check parameter 209, [Drive Status 1], bits 12 & 13 for unexpected source selections. 6. Check parameter 216 [Dig In Status] to see if inputs are selecting an alternate source. 7. Reprogram digital inputs to correct "Speed Sel x" option.

Motor and/or drive do not accelerate to commanded speed.

Cause(s)	Indication	Corrective Action
Acceleration time is excessive.	None	Reprogram [Accel Time x].
Excess load or short acceleration times force the drive into current limit, slowing or stopping acceleration.	None	Check [Drive Status 2], bit 10 to see if the drive is in Current Limit. Remove excess load or reprogram [Accel Time x].
Speed command source or value is not as expected.	None	Check for the proper Speed Command by using Steps 1 through 7 above.
Programming is preventing the drive output from exceeding limiting values.	None	Check [Maximum Speed] and [Maximum Freq] (parameters 082 and 055) to assure that speed is not limited by programming.

Motor operation is unstable.

Cause(s)	Indication	Corrective Action
Motor data was incorrectly entered or Autotune was not performed.	None	1. Correctly enter motor nameplate data. 2. Perform "Static" or "Rotate" Autotune procedure.



Drive does not reverse motor direction.

Cause(s)	Indication	Corrective Action
Digital input is not selected for reversing control.	None	Check [Digital Inx Sel]. Choose correct input and program for reversing mode.
Digital input is incorrectly wired.	None	Check input wiring.
Direction mode parameter is incorrectly programmed.	None	Reprogram [Direction Mode] for analog "Bipolar" or digital "Unipolar" control.
Motor wiring is improperly phased for reverse.	None	Switch two motor leads.
A bipolar analog speed command input is incorrectly wired or signal is absent.	None	1. Use meter to check that an analog input voltage is present. 2. Check wiring. Positive voltage commands forward direction. Negative voltage commands reverse direction.

Stopping the drive results in a Decel Inhibit fault.

Cause(s)	Indication	Corrective Action
The bus regulation feature is enabled and is halting deceleration due to excessive bus voltage. Excess bus voltage is normally due to excessive regenerated energy or unstable AC line input voltages. Internal timer has halted drive operation.	Decel Inhibit fault screen. LCD Status Line indicates "Faulted".	1. See Attention statement on page 6 . 2. Reprogram parameters 161/162 to eliminate any "Adjust Freq" selection. 3. Disable bus regulation (parameters 161 & 162) and add a dynamic brake. 4. Correct AC input line instability or add an isolation transformer. 5. Reset drive.

Manually Clearing Faults

Step	Key(s)
<ol style="list-style-type: none">1. Press Esc to acknowledge the fault. The fault information is removed so that you can use the Human Interface Module (HIM).2. Address the condition that caused the fault. The cause must be corrected before the fault can be cleared.3. After corrective action has been taken, clear the fault by one of these methods:<ul style="list-style-type: none">• Press Stop• Cycle drive power• Set parameter 240 [Fault Clear] to "1."• "Clear Faults" on the Human Interface Module (HIM) Diagnostic menu.	 

Notes:

Rockwell Automation Support

Rockwell Automation provides technical information on the Web to assist you in using its products.

At <http://www.rockwellautomation.com/support>, you can find technical manuals, technical and application notes, sample code and links to software service packs, and a MySupport feature that you can customize to make the best use of these tools. You can also visit our Knowledgebase at <http://www.rockwellautomation.com/knowledgebase> for FAQs, technical information, support chat and forums, software updates, and to sign up for product notification updates.

For an additional level of technical phone support for installation, configuration, and troubleshooting, we offer TechConnectSM support programs. For more information, contact your local distributor or Rockwell Automation representative, or visit <http://www.rockwellautomation.com/support/>.

Installation Assistance

If you experience a problem within the first 24 hours of installation, review the information that is contained in this manual. You can contact Customer Support for initial help in getting your product up and running.

United States or Canada	1.440.646.3434
Outside United States or Canada	Use the Worldwide Locator at http://www.rockwellautomation.com/support/americas/phone_en.html , or contact your local Rockwell Automation representative.

New Product Satisfaction Return

Rockwell Automation tests all of its products to ensure that they are fully operational when shipped from the manufacturing facility. However, if your product is not functioning and needs to be returned, follow these procedures.

United States	Contact your distributor. You must provide a Customer Support case number (call the phone number above to obtain one) to your distributor to complete the return process.
Outside United States	Please contact your local Rockwell Automation representative for the return procedure.

Documentation Feedback

Your comments will help us serve your documentation needs better. If you have any suggestions on how to improve this document, complete this form, publication [RA-DU002](#), available at <http://www.rockwellautomation.com/literature/>.

U.S. Allen-Bradley Drives Technical Support - Tel: (1) 262.512.8176, Fax: (1) 262.512.2222, E-mail: support@drives.ra.rockwell.com
Online: www.ab.com/support/abdrives



PN-211781

Allen-Bradley, Rockwell Software, Rockwell Automation, PowerFlex, RSLinx, DriveExplorer, DriveExecutive, ControlFLASH, and TechConnect are trademarks of Rockwell Automation, Inc.
Trademarks not belonging to Rockwell Automation are property of their respective companies.

www.rockwellautomation.com

Power, Control and Information Solutions Headquarters

Americas: Rockwell Automation, 1201 South Second Street, Milwaukee, WI 53204-2496 USA, Tel: (1) 414.382.2000, Fax: (1) 414.382.4444
Europe/Middle East/Africa: Rockwell Automation NV, Pegasus Park, De Kleetlaan 12a, 1831 Diegem, Belgium, Tel: (32) 2 663 0600, Fax: (32) 2 663 0640
Asia Pacific: Rockwell Automation, Level 14, Core F, Cyberport 3, 100 Cyberport Road, Hong Kong, Tel: (852) 2887 4788, Fax: (852) 2508 1846

Publication 20B-IN019E-EN-P - July 2013
Supersedes Publication 20B-IN019D-EN-P - June 2013

PN-211781
Copyright © 2013 Rockwell Automation, Inc. All rights reserved. Printed in the U.S.A.