



ACC-5595

2 Gb/s Reflective Memory Hub Assembly

Features

- For use with GE Intelligent Platforms 5565 Reflective Memory network of products
- Provides up to eight ports using small form factor pluggable (SFP) transceivers
- Hub assemblies can be cascaded with a maximum of 256 nodes
- Automatically bypasses defective or disconnected nodes in a fiber-optic network
- Automatic bypass can be optionally controlled by the loss of signal or by the loss of sync pattern
- Each port regenerates the serial optical signal, eliminating link losses and reducing jitter
- Configurable for use with cables up to 10 km in length
- 10BaseT Ethernet TCP/IP port for remote access and control
- RS232 port for local access and control
- Optional 19 - inch 1U rack mount or desktop enclosure
- Internal universal power supply
- Dark on Dark option turns off the board's transmitter if the receiver does not detect a signal (available for firmware versions 02.00 and later)

The ACC-5595 is a managed hub designed to operate with the GE Intelligent Platforms 5565 family of Reflective Memory real-time network products. The Reflective Memory hub can automatically bypass ports when it detects a loss of signal or the loss of valid synchronization patterns, allowing the other nodes in the network to remain operational. Since the optical ports are implemented with small form factor pluggable (SFP) transceivers, only the required ports need to be populated. The ACC-5595 SFP transceivers can be a combination of either multimode (short distance) or single-mode (long distance) transceivers. This feature permits a cost saving in small networks as well as system optimization. For larger networks, several ACC-5595 assemblies can be cascaded, permitting a managed hub array with up to 256 nodes. Each port regenerates the serial optical signal, eliminating the problems with insertion losses and cable attenuation. Signal regeneration also reduces jitter. The RS232 port gives you the ability to monitor and control your Reflective Memory network through a simple PC serial port. The Ethernet port feature allows you to monitor and control the hub from great distances through a local area network (LAN) or via a Web browser.

As an option, the ACC-5595 can be configured as a 19-inch 1U rack-mountable enclosure or as a desktop enclosure. The universal power supply permits operation with nearly any international power standard.

The ACC-5595 automatically bypasses ports when the absence of valid synchronization patterns is detected. Three LEDs, adjacent to each port, provide a visual indication of the port status. Additional status indications and modes of operation are available through either the serial port or the Ethernet port.

Status information includes the detection of installed transceivers, the detection of signal (light), the detection of valid synchronization patterns and the port operation speed (2 Gb/s). Control registers allow the channel bypass to be based on the absence of a single valid synchronization pattern or multiple synchronization patterns. A bypass can also be based simply on the loss of a signal (light). In addition, each port can be manually forced either active or bypassed regardless of the status indicators.

An additional control register permits the transmitter of any port to be manually disabled.



ACC-5595 2 Gb/s Reflective Memory Hub Assembly

Front panel manual switches include a recessed momentary reset switch and a Gang Select switch. The Gang Select switch configures the ACC-5595 ports as one loop of eight ports or two separate loops of four ports each.

Functional Characteristics

- Multimode Port Wavelength: 830 to 860 nm
- Multimode Cable Length: 300 m (maximum)
- Single-Mode (10km) Port Wavelength: 1,300 to 1,335 nm
- Single-Mode (10 km) Cable Length: 10 km (maximum)
- Single-Mode (80 km) Port Wavelength: 1,540 to 1,570 nm

- Single-Mode (10 km) Cable Length: 80 km (maximum)
- Dark on Dark: The Dark on Dark option turns off the board's transmitter if the receiver does not detect a signal (available for firmware versions 02.00 and later).

connection. The remote interface is controlled by the use of standard HTML-based Web browsers. The user interface presents status data, such as "loss of signal" and "sync detect" information. Bypass mode, "Dark on Dark" and the ability to force each port on/off or automatic are supported. These settings are retained in NVRAM.

Ethernet Controller: 10BaseT interface is compliant with Transmission Control Protocol/Internet Protocol (TCP/IP) standards. Each hub assembly will have a unique MAC address. The hub assembly can operate on either a LAN or a wide area network (WAN).

The ACC-5595 includes a remote user interface available through a standard Ethernet

Block Diagram

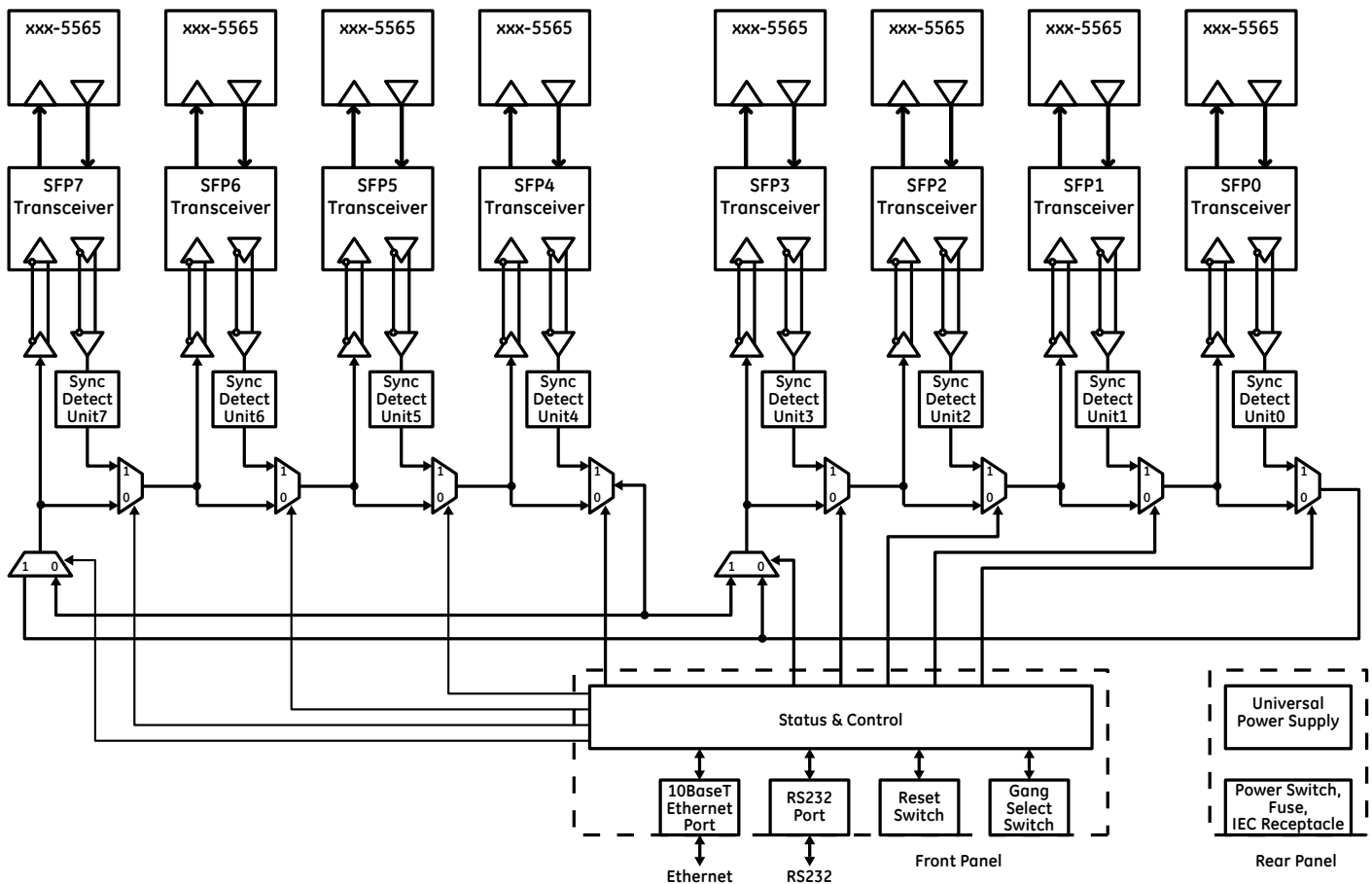

ACC-5595 2 Gb/s Reflective Memory Hub Assembly

Cascade of Three ACC-5595s with 24 Nodes

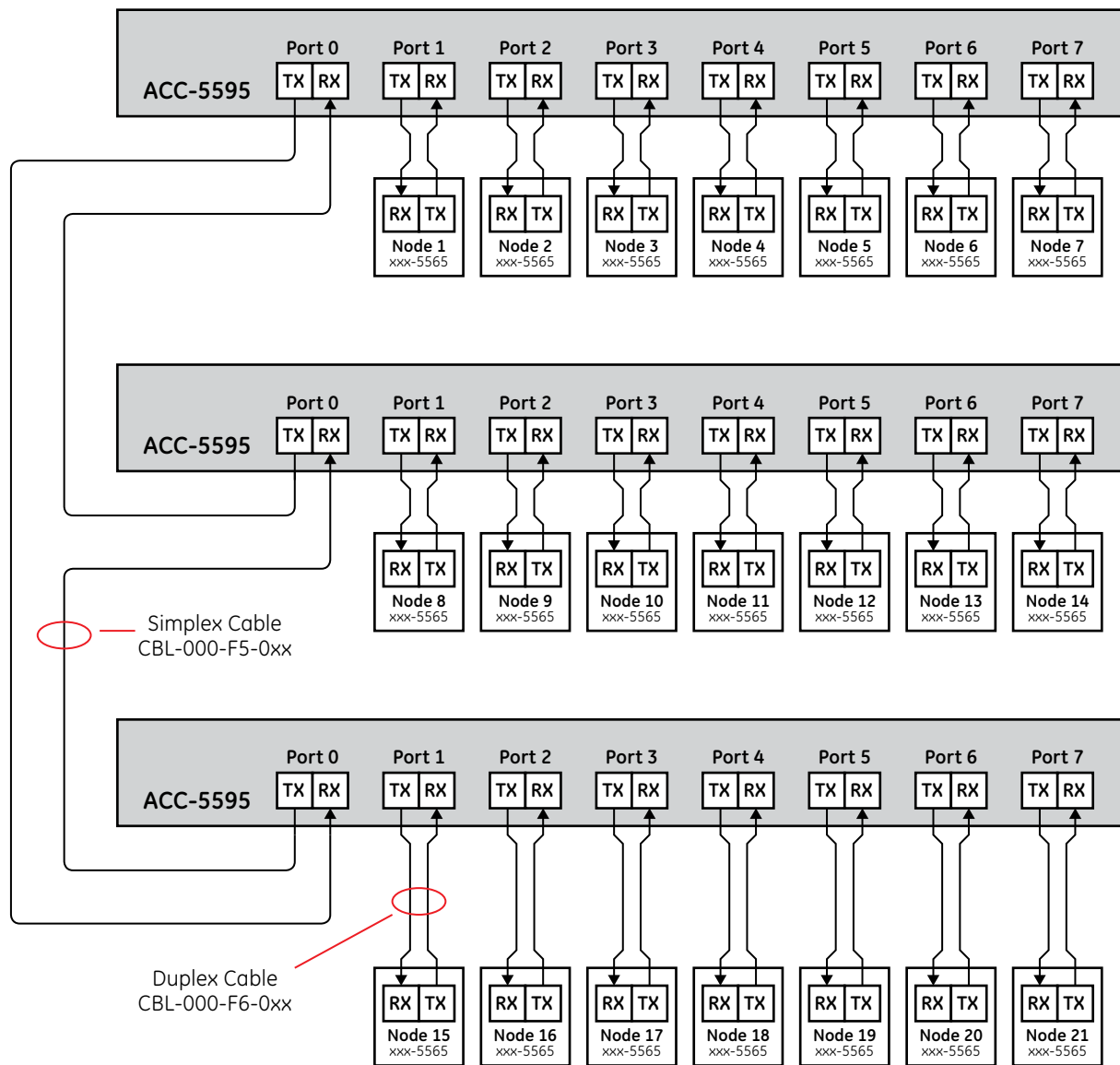

ACC-5595 2 Gb/s Reflective Memory Hub Assembly

Specifications

Desktop Assembly Dimensions

- 16.73 inches wide by 10.0 inches deep by (1U) 1.72 inches high. Dimensions do not include nonskid self-adhesive feet.

Rack Mount Assembly Dimensions

- The basic dimensions are the same as the desktop assembly, but include two 1U rack mount brackets for the standard 19-inch rack.

Front Panel Connectors

- 8 SFP transceivers. The SFP receptacles not populated with transceivers contain EMI dust plugs. There is one RJ45 Ethernet connector and one 9-pin female D-subminiature RS232 connector.

Cabling

- Each installed SPF transceiver requires either one Duplex LC-type fiber-optic cable or two Simplex LC-type fiber-optic cables. The Simplex cables are best suited for cascading hubs. The Duplex cables can be used for all other interconnectivity.

Rear Panel Connectors

- A power entry module that includes a power ON/OFF switch, a 4A/250V fuse, and a globally accepted IEC receptacle.

Fuse

- 1 A, 250 V, 5 × 20 mm, fast acting, IEC 60127-2 standard glass or equivalent

MTBF

- Total fit x qty: 2,317,3641
- MTBF (hours): 431,524.76

Power Requirements

- 90 to 264VAC
- 47 to 440Hz
- 25W. Power supply and power entry module meet safety standards: UL, C-UL: UL 1950 TUV: EN69050 CE: EN55022, EN61000-4-2, 3, 4, 5; EN61000-3-2

Environmental

- Temperature
 - Operating: 0° to +65°C
 - Storage: -40° to +85°C
- Relative Humidity
 - Operating: 20% to 80%, noncondensing
 - Storage: 20% to 80%, noncondensing

Regulatory Compliance

- European Union (CE Mark)
 - EN55024
 - EN55022 Radiated Emissions Class A
 - EN55022 Conducted Emissions Class A
 - EN61000-4-2 (ESD)
 - EN61000-4-3 (Radiated Immunity)
 - EN61000-4-4 (EFT)
 - EN61000-4-5 (Surge)
 - EN61000-4-6 (Conducted RF)
 - EN61000-4-8 (Power Frequency Magnetic Fields)
- United States FCC Part 15, Class A
- Canada ICES-003, Class A
- UL60950
- EN60950(LVD)

Ordering Information

	A	B	C
ACC-5595	-		0

A = Enclosure Options

- 0 = Reserved 1 = Reserved
- 2 = Rack Mount or Desktop

B = Number of Single-Mode (10km) Pluggable Transceivers

- 0, 1, 2, 3, 4, 5, 6, 7, or 8

C = Number of Multimode Pluggable Transceivers

- 0, 1, 2, 3, 4, 5, 6, 7, or 8

Simplex Cable Specifications

Fiber-optic cable - Multimode 62.5 micron core

	A	B	C
CBL-000-F5	-		

ABC = Cable Lengths

000 = 0.5 ft (01.5 m)	005 = 50 ft (15.24 m)	011 = 350 ft (106.68 m)
001 = 1 ft (0.31 m)	006 = 80 ft (24.40 m)	012 = 500 ft (152.15 m)
002 = 5 ft (1.52 m)	008 = 150 ft (45.72 m)	013 = 574 ft (175 m)
003 = 10 ft (3.04 m)	009 = 200 ft (60.98 m)	014 = 656 ft (200 m)
004 = 25 ft (7.62 m)	010 = 250 ft (76.20 m)	016 = 1,000 ft (304.30 m)

Duplex Cable Specifications

Fiber-optic cable - Multimode 62.5 micron core

	A	B	C
CBL-000-F6	-		

ABC = Cable Lengths

000 = 3 ft (1 m)	006 = 98 ft (30 m)	014 = 656 ft (200 m)
001 = 6 ft (2 m)	007 = 164 ft (50 m)	015 = 721 ft (220 m)
002 = 10 ft (3 m)	008 = 230 ft (70 m)	016 = 754 ft (230 m)
003 = 16 ft (5 m)	011 = 426 ft (130 m)	017 = 820 ft (250 m)
004 = 32 ft (10 m)	012 = 492 ft (150 m)	018 = 885 ft (270 m)
005 = 66 ft (20 m)	013 = 557 ft (170 m)	019 = 984 ft (300 m)

Note:

Sum of B + C + D Modules should be less than or equal to 8.

About GE Intelligent Platforms

GE Intelligent Platforms, a General Electric Company (NYSE: GE), is an experienced high-performance technology company and a global provider of hardware, software, services, and expertise in automation and embedded computing. We offer a unique foundation of agile, advanced and ultra-reliable technology that provides customers a sustainable advantage in the industries they serve, including energy, water, consumer packaged goods, government and defense, and telecommunications. GE Intelligent Platforms is a worldwide company headquartered in Charlottesville, VA and is part of GE Home and Business Solutions. For more information, visit www.ge-ip.com.

GE Intelligent Platforms Contact Information

Americas: 1 800 433 2682 or 1 434 978 5100

Global regional phone numbers are listed by location on our web site at www.ge-ip.com/contact

www.ge-ip.com

